

CritiCool[®]

User Manual



Conformity according to the Council Directive 93/42/EEC



Belmont Medical Technologies
780 Boston Road
Billerica, MA 01821 USA
Technical Service
885-397-4547 (USA)
+1-978-663-0212 (WORLDWIDE)
www.BelmontMedTech.com

European Representative:



Emergo Europe
Westervoortsedijk 60
6827 at Arnhem
The Netherlands

Switzerland Authorized Representative:



Medenvoy Switzerland
Gotthardstrasse 28
6302 ZUG
Switzerland

The user manual and translations are available by digital version:



1) Visit the Belmont website under Resources:
<https://belmontmedtech.com/resources>

2) Scan the QR code to the left.

To request a printed or previous version of a user manual, please contact:
resources@belmontmedtech.com

Copyright by Belmont Medical Technologies. All RIGHTS RESERVED
Registered trademarks are the intellectual property of their respective holders.

Use Of Manual

The purpose of this manual is to help medical personnel trained on the usage of this system understand and operate the system. It is important that you read this manual and familiarize yourself thoroughly with its contents before you attempt to operate the system. If you do not understand any part of this manual, or if anything is unclear or ambiguous in any way, please contact your Belmont Medical Technologies representative.

The CritiCool® system described in this manual has been designed to meet international safety and performance standards. Only trained medical personnel may operate the system, and these operators must first have a full understanding of the proper operation of the system.

The information provided in this manual is not intended to replace regular medical training procedures.

This manual should always accompany the system. All qualified personnel operating the system should know the location of the manual. For additional copies of this manual, please contact your Belmont Medical Technologies representative.

Training

Belmont Medical Technologies or its authorized distributor will provide training for the system user according to the intended use of the system.

It is the responsibility of the hospital management to ensure that only users trained to use the equipment safely operate the system.

Operator Profile

Connections and system settings should be performed by a clinical expert in thermoregulation.

Product Complaints/Incident Reporting

Report any complaint or problem in the quality, reliability, safety, or performance of this product to Belmont Medical Technologies. If the device has caused or added to patient injury, immediately report the incident to the Belmont Medical Technologies Authorized Representative and Competent Authority of the respective member state or country.

Important Notice

No part of this manual may be reproduced or copied in any form by any graphic, electronic or mechanical means - including photocopying, scanning, typing or information retrieval systems - without advanced written permission from Belmont Medical Technologies.

Disclaimer

Belmont Medical Technologies is not responsible for any consequential or incidental damages or expenses of any kind, impairment of or damage to other goods caused by the following:

- a. Installed, operated, maintained contrary to Belmont Medical Technologies instructions, notes or warnings under this manual.
- b. Ignoring any of the warnings, precautions and safety measures indicated in this manual.
- c. Replacement, repair or alteration not performed by Belmont Medical Technologies or authorized personnel.
- d. The use of accessories and other parts or equipment made by other manufacturers, whether or not warranted by such manufacturers, which have been attached or connected to the system after installation, unless such accessories and other parts have been supplied and attached or installed by Belmont Medical Technologies.
- e. Using the system in a contrary manner than indicated in this manual or using the system for any purpose other than indicated in the manual.

TABLE OF CONTENTS

Use Of Manual	3
Chapter 1: Safety Precautions	11
Definitions	11
Intended Use	11
Patient Target Group	11
Contraindications.....	11
Warnings	11
Precautions.....	12
EMC Safety	13
Improper Use.....	13
Labels.....	14
Label Symbols	15
Chapter 2: System Description	17
General Description.....	17
Clinical Benefits	17
CritiCool® System.....	18
CritiCool® Device.....	18
External Features	19
Front View	19
Side View	20
Rear Panel	21
CureWrap®	22
Description and Intended Use.....	22
Wrap Material.....	22
Usage Duration	22
Risk of Reuse.....	22
Selected Wrap Design.....	24
Accessories	24
Temperature Probes	24
Detachable Electric Power Cable & Plug.....	27
Connecting Tubes for Wrap	27
Male Connector for Draining Water Tank	28
Spare Water Filter	28
Handle	28
CliniLogger™ (Optional).....	28
Temperature Splitter (Optional)	29
System Specifications	29
CritiCool® Technical Specifications.....	30
CliniLogger™ Technical Specifications.....	33
Chapter 3: Installation	34
Pre-installation Requirements	34
Space and Environmental Requirements	34
Electrical Requirements	34
Equipment List	34
Unpacking and Inspection	35
Unpacking CritiCool from the Box.....	35
Assembling the Handle	36

Moving the Unit	37
Preparation:.....	37
Locking and Unlocking the Trolley Wheels	37
Packing CritiCool for Shipment	37
Chapter 4: Operating Instructions	38
General.....	38
CritiCool Functions	38
Controls, Functions, Indicators and Connections.....	39
Main Power Switch.....	39
CritiCool® Screen Controls.....	39
QCC— Quick Coupling Connectors.....	40
Temperature Probe Sockets	40
Patient Thermoregulation – Step by Step Operation	41
Operating the System	42
Connecting the Water Hoses (Tubes) to CritiCool.....	44
Inserting and Attaching Temperature probes	45
Activating the System.....	46
Wrapping the Patient.....	47
The Control Panel	48
Patient Mode	49
The Main Menu	53
Standby Mode	54
Mode Select	55
Temperature Graph.....	57
Settings	58
Services	60
Modes of Operation.....	63
Normothermia Management	74
Replacing the Wrap.....	76
Operation Panel Messages and Alerts.....	77
TTM Mode Messages	78
Controlled Rewarming Mode Messages	81
Chapter 5: Ordering Information.....	83
Equipment and Accessories	83
Available Wraps	83
Available Accessories	84
Chapter 6: Maintenance	87
Introduction.....	87
Service Information	87
Routine & Preventive Maintenance	88
Routine Maintenance Overview	89
Cleaning & Disinfecting External Surfaces	89
Water Circuit Disinfection Instructions	91
Thermal Disinfection (Self-Cleaning)	95
System Check Service	95
Filter Replacement.....	97
Chapter 7: Troubleshooting	98
General.....	98
Troubleshooting Guide	98
Chapter 8: Clinilogger™ Installation And Operating Instructions	111

Overview and Installation	111
Introduction	111
Using the CliniLogger™ Application.....	111
The CliniLogger™ Software	111
Installing the Software.....	111
Using the CliniLogger™ Viewer Application	114
Downloading Data.....	114
Viewing Downloaded Data.....	116
CliniLogger™ Viewing Panel.....	118
Converting to Excel.....	125
Ending a Viewing Session	126
Appendix A: EMI / EMC Information	127
Appendix B: Waste Electrical & Electronic Equipment (WEEE).....	129

LIST OF FIGURES

Figure 1: Label Placement for the CritiCool® Device	14
Figure 2: Front View	19
Figure 3: Side View	20
Figure 4: Rear View	21
Figure 5: Measurements	23
Figure 6: Disposable Core Temperature Probe Connection	26
Figure 7: Disposable Surface Temperature Probe Connection	27
Figure 8: Handle Assembly	36
Figure 9: Self-Test Screen	42
Figure 10: Halt Error	43
Figure 11: Mode Select Upon Startup	46
Figure 12: Main Screen	47
Figure 13: The Control Panel	48
Figure 14: Settings Screen 1	50
Figure 15: Patient Mode Changed. Check Set Point	50
Figure 16: Main Menu	53
Figure 17: Standby Mode	54
Figure 18: Select Mode Panel	55
Figure 19: Temperature Graph	57
Figure 20: Settings Screen 1	58
Figure 21: Settings Screen 2	59
Figure 22: Settings Screen 3	59
Figure 23: Settings Screen 4	60
Figure 24: Service Menu	60
Figure 25: Start Emptying Panel	61
Figure 26: Emptying Water - Performing Panel	62
Figure 27: Check Water Tubes	62
Figure 28: Select Mode Controlled Rewarming	67
Figure 29: Switching to Rewarming Message	67
Figure 30: Target Temperature Setting Panel	69
Figure 31: Holding Core Temp for First Step of Rewarming	70
Figure 32: Target Temperature Has Been Reached	71
Figure 33: Temperature Regulation Paused Message	72
Figure 34: Normothermia Mode	75
Figure 35: Out of Normothermia Range	76
Figure 36: Adjustable Alarm Limits	77
Figure 37: Low Core Temperature Message	78
Figure 38: TTM Mode: Core Readout Too Low Message	79
Figure 39: Thermoregulation is Continuing Message	80
Figure 40: Controlled Rewarming Mode: Core Readout Too Low Message	81
Figure 41: Thermoregulation is Continuing Message	82
Figure 42: Selecting System Check	96
Figure 43: System Check in Progress	96
Figure 44: Male Draining Connector Attached to Connecting Water Hoses (for Emptying)	103
Figure 45: CliniLogger™ Initialization	112

Figure 46: CliniLogger™ Installation.	112
Figure 47: Start Installation.	113
Figure 48: Installation Progress.	113
Figure 49: Installation Complete.	114
Figure 51: CliniLogger™ Application Window.	115
Figure 52: CliniLogger™ Window.	116
Figure 53: Choose CliniLogger™ File Window.	116
Figure 54: Complete Message.	117
Figure 55: CliniLogger™ Viewing Panel.	118
Figure 56: Graphic Display Area.	119
Figure 57: Example: Functional Status Area.	120
Figure 58: Example: Modes and Errors Area.	120
Figure 59: Example of Modes and Error Area.	124
Figure 60: Section of Excel Table.	125
Figure 61: Section of Graphic Chart.	126

LIST OF TABLES

Table 1: Key to Label Symbols	15
Table 2: CureWrap®	24
Table 3: Part Numbers: Disposable Temperature Probes and Associated Cables	27
Table 4: CritiCool® screen keys	39
Table 5: Wrap Information.....	83
Table 6: CritiCool Infant Reusable Accessory Kit (PN# 200-00320)	84
Table 7: CritiCool Adult Reusable Accessory Kit (PN# 200-00300)	84
Table 8: CritiCool Infant Disposable Accessory Kit (PN# 200-00330).....	85
Table 9: CritiCool Adult Disposable Accessory Kit (PN# 200-00310)	85
Table 10: Accessories.....	86
Table 11: Inspection and Maintenance Schedule	88
Table 12: CritiCool System Malfunction (no message) Troubleshooting Guide	99
Table 13: CritiCool Controlled Rewarming Mode Troubleshooting Guide	100
Table 14: Draining CritiCool / Water Tank Overfilled	103
Table 15: CritiCool System Technical Alarm Messages Troubleshooting Guide	104
Table 16: CritiCool System Technical Alarm Messages Troubleshooting Guide	105
Table 17: CritiCool System/Clinical Messages Troubleshooting Guide	106
Table 18: CritiCool “Core Readout Too Low” Safety Message Troubleshooting Guide	107
Table 19: CritiCool System Messages (Notes) (v6.4 Only) Troubleshooting Guide.....	108
Table 20: CritiCool Clinical Messages (Notes) Troubleshooting Guide.....	109
Table 21: CritiCool Clinical Messages (Notes) Troubleshooting Guide.....	110
Table 22: Zoom Tool Buttons.....	122
Table 23: CliniLogger Mode Codes	124
Table 24: Guidance and Manufacturer’s Declaration – Emissions	127
Table 25: Guidance and Manufacturer’s Declaration – Immunity	128

Chapter 1: Safety Precautions

Definitions

- WARNING!** *Indicates a condition that may endanger the patient or the system operator*
- CAUTION!** *Indicates a condition that may damage the equipment*
- NOTE:** *Indicates ways in which the system's operation can be made more efficient.*

Intended Use

CritiCool® is a thermal regulating system, indicated for monitoring and controlling patient temperature.

Patient Target Group

CritiCool can be used with infant, pediatric and adult patients.

Contraindications

CureWrap® should not come into contact with open wounds. Caution should be taken when using CureWrap with patients with underlying skin conditions.

Warnings

1. The physician must be notified if the patient's temperature does not respond properly, does not reach the prescribed temperature, or if there is any change in the prescribed temperature range. Failure to inform the physician may result in injury to the patient.
2. The misuse of the temperature regulation equipment can be potentially harmful to the patient.
3. Use only sterile water or 0.22 µm filtered water. Sterile water is recommended.
4. Do not plug wet probes into the sockets of the CritiCool® device.
5. The user should verify that no fluids are present at the skin/wrap interface during the procedure. Failure to do so can cause lesions on the patient's skin.
6. Following the procedure, a pattern resembling the wrap may appear for a short period of time on the patient's skin.
7. Pressure sores may appear or develop when soft tissue is compressed between a bony prominence and external surface. The use of the CritiCool® system does not prevent this from happening.

8. Routine care should be taken during long thermoregulation procedures to prevent pressure sores.
9. Do not lift or move the patient by means of the wrap. This may cause tearing and water leakage.
10. Prevent any thermal isolation, such as a pillow or other items, between the Wrap and the patient's body.
11. Do not apply heating/cooling to lower extremities during aortic cross clamping. Thermal injury may occur if heating/cooling is applied to ischemic limbs.
12. Wraps cannot be placed over transdermal patches.
13. Wraps should not come in contact with open wounds.
14. CureWrap® should not be in direct contact with open, widespread skin lesions such as burns or dermatitis.
15. Caution should be taken when using CureWrap® with patients that have underlying skin conditions.
16. Do not touch the ribbon cable behind the display and the patient simultaneously.
17. Patients being thermoregulated should be closely monitored at all times.

Precautions

1. Follow the warning notes listed in the various sections of this manual.
2. Only trained personnel, familiar with all system operating procedures and certified only by Belmont Medical Technologies or authorized agents of Belmont Medical Technologies are allowed to use the CritiCool® system.
3. If moisture or leaks are discovered in the connecting hose and/or Wrap, turn off the CritiCool® device, disconnect the power cable from its power source, and correct the problem before proceeding.
4. If the system sounds an alarm and/or presents a display other than the standard Belmont Medical Technologies display, the operator should proceed according to the display message and/or the troubleshooting instructions (see "[Troubleshooting Guide](#)").
5. Avoid folds in the Wrap—these may obstruct water flow.
6. Do not block the CritiCool® system ventilation grilles. Air must be able to flow freely in and out in order to keep the system cool.
7. Do not use de-ionized water or water created through reverse osmosis because it may promote corrosion of the metal components of the system.
8. When X-ray imaging is performed on a patient wearing a wrap, shadows from the wrap may appear on the X-ray film. Connecting water hoses should not be connected to the patient during imaging as they contain metal.
9. Avoid inserting any sharp object between the patient and the Wrap.
10. Read all manufacturers' instructions associated with the temperature probes or temperature probe adapters supplied by Belmont Medical Technologies.

11. Accessories from one system should not be moved or switched out with those from another system to avoid cross-contamination.

EMC Safety

For safe use of the CritiCool[®], it is required to keep the CritiCool[®] at a safe distance from systems emitting radio frequency (RF) energy.

Refer to Appendix B for recommended separation distances between the CritiCool[®] and RF source.

CAUTION! *Power interruptions shorter than 10 minutes return the machine to the mode that was operating before the interruption with a 3-beep alarm. Power interruptions of 10 minutes or longer return the machine to the parameters selected in the Settings menu.*

IMPORTANT! *Make sure to read the messages to ensure correct reactivation of the machine. If a power outage occurs when using Controlled Rewarming Mode, the user should reinitiate Controlled Rewarming Mode. See page 72 for instructions.*

Improper Use

Improper use of the CritiCool[®] system can lead to skin lesions, electrical hazards, and severe changes in body temperature.

CAUTION! *U.S. Federal law restricts this system to sale by or on the order of a physician.*

Labels





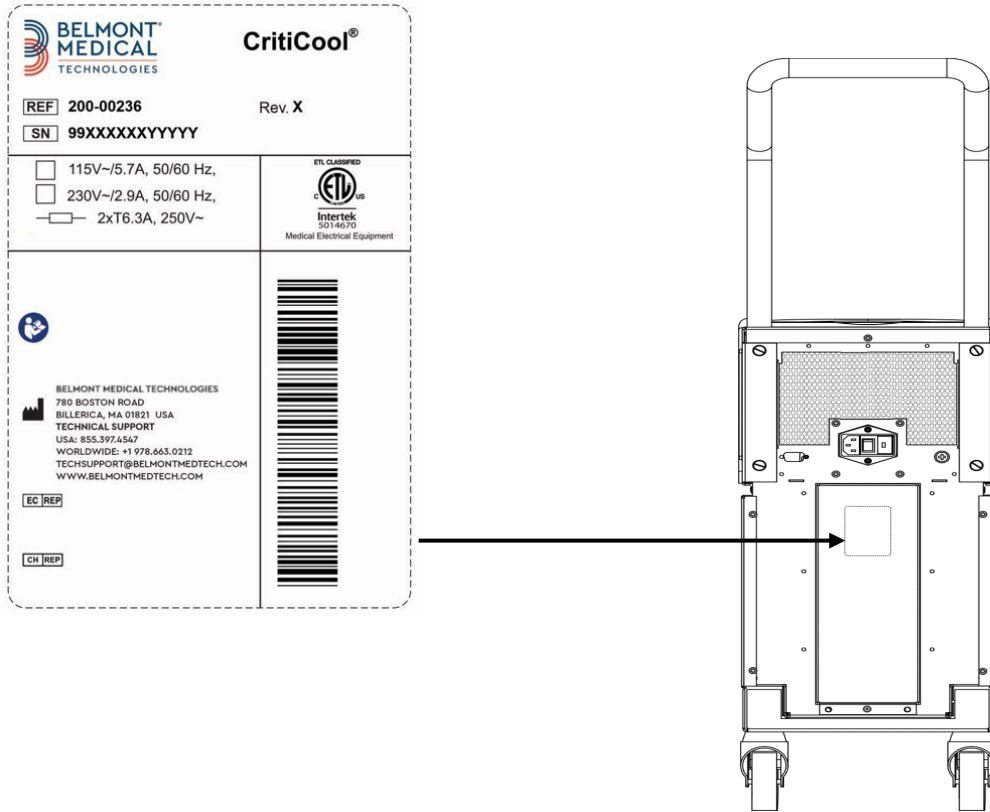







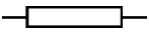

CritiCool® System Labels









Figure 1: Label Placement for the CritiCool® Device



Label Symbols

Table 1: Key to Label Symbols

Description	Symbol
CE mark of conformity indicates that the product has received the European approval for MDD 93/42/EEC.	
AC Voltage	
Fuse	
The serial number for this product	
Catalogue part number	
European Authorized Representative	
Switzerland Authorized Representative	
Caution – refer to user manual	
Type BF equipment	
Recycle for WEEE	
Date of manufacture	
Name of manufacturer	
Country of manufacturer	
Do not push	
Refer to instruction manual / booklet	

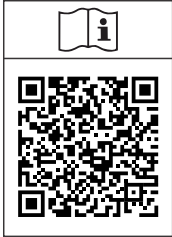
Description	Symbol
Restricts the sale and use of this instrument to qualified medical personnel only.	
Unique Device Identifier	
Instructions for Use	
Does not contain natural rubber latex	
Medical Device	
Do Not Reuse	
Not safe in MRI	
Use sterile or 0.22 μ filtered water only. Tap water usage is not permitted.	
E-IFU	

Chapter 2: System Description

General Description

A growing number of cases require a solution for controlling patient temperature in various hospital settings. Therapeutic hypothermia, Targeted Temperature Management (TTM) or simply controlling normothermia is beneficial and sometimes vital.

The CritiCool® system controls and maintains temperature in an effective and precise manner. The desired temperature is preset by the physician with a possible range of target temperatures from Hypothermia to Normothermia.

The system is composed of two elements, the CritiCool® device, and the CureWrap®. The CritiCool® device functions as a control unit and a cooling/heating pump, which circulates water. The control unit constantly monitors the patient's core temperature through specific probes and using its on-board body temperature control algorithm at 133 millisecond intervals, delivers the optimum water temperature to reach the desired set point temperature. The cooling/heating pump brings the water to the required temperature and the pump circulates it through the specially designed flexible and single piece CureWrap®.

The CureWrap® is designed to be in close contact with a large area of the body, thus allowing optimization of energy transfer.

WARNING! *The Belmont Medical Technologies wrap is proprietary to Belmont Medical Technologies and this is the only wrap authorized to be used with the CritiCool® system. Use of any other wrap with the system may harm the patient.*

Clinical Benefits

The use of active thermoregulation (TTM and normothermia) treatment has shown that the benefits outweigh the risks, with improvements in patient morbidity and mortality.

CritiCool® System

The CritiCool® system consists of the following elements:

- CritiCool® device
- CureWrap®
- Accessories

CritiCool® Device

The CritiCool® device has a microprocessor that controls the water temperature flowing into the wrap worn by the patient.

The water temperature is controlled and maintained to the desired set point by measuring the actual patient temperature (core and surface) and adjusting the temperature of the wrap accordingly.

Timed pauses of flow during clinical operation regulate the water pressure and water flow in CureWrap. During the initial phase of regulation, the flow cycle is 12 minutes ON (water flows through the wrap) and 1 minute OFF (water recirculates within CritiCool®; no flow through the wrap) in both TTM and Normothermia modes.

In a steady state (when the core temperature is within the set point range), the cycle is 12 minutes ON and 12 minutes OFF.

If the difference between the patient's core temperature and the set point temperature exceeds 0.3°C at any time during a timed pause, water will return to the wrap to adjust the patient's temperature.

The CritiCool® device is equipped with a handle for easy transport.

External Features

Front View

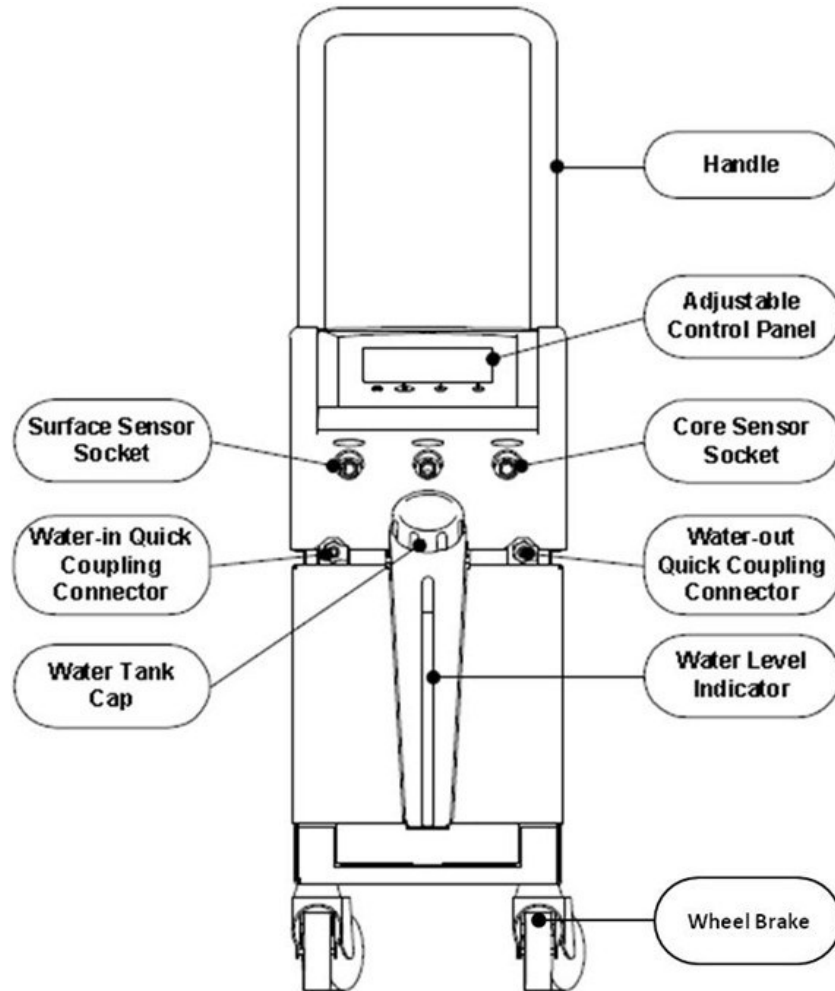

Figure 2: Front View

Side View

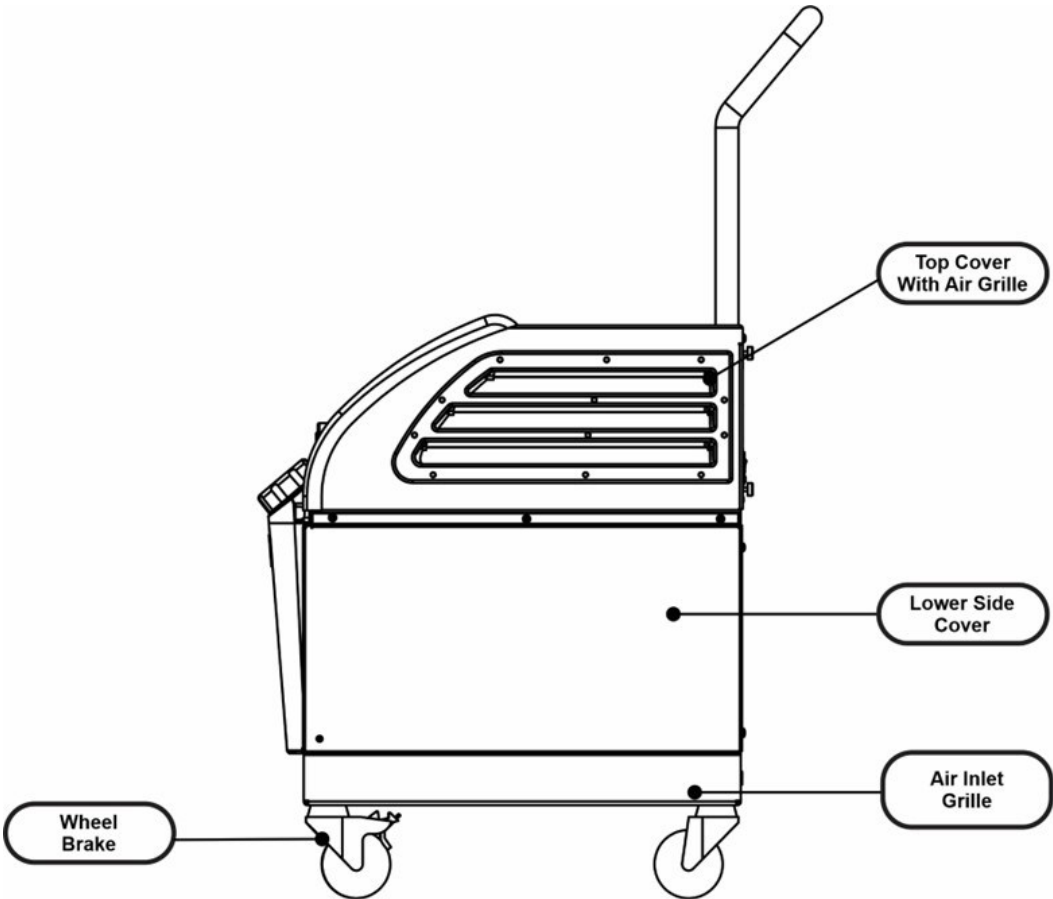

Figure 3: Side View

Rear Panel

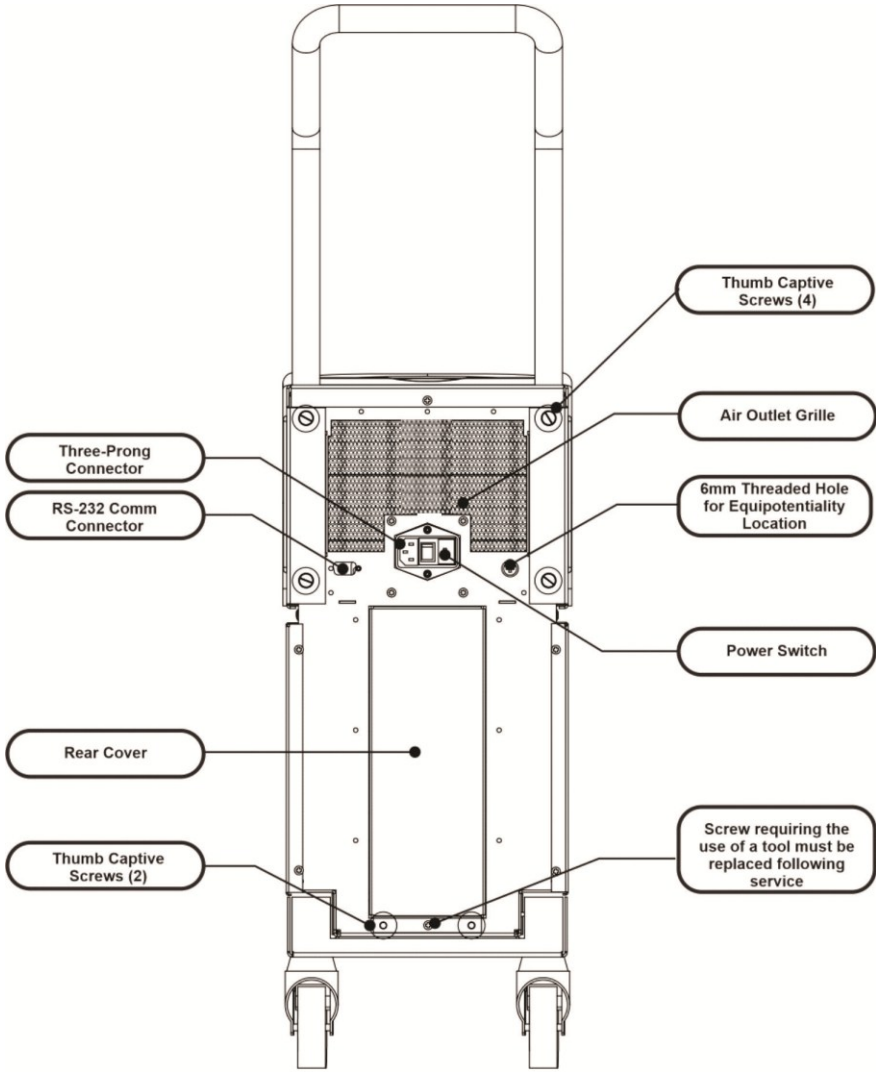

Figure 4: Rear View

CureWrap®

Description and Intended Use

The wrap is a one-piece wrap with a one-inflow and one or two return water connections that circulate water in the wrap channels.

The Wrap is:

- Disposable
- Biocompatible
- Antistatic
- Adjustable
- Not made with natural rubber latex

Each section of the Wrap is separately wrapped around the appropriate area of the patient (e.g., chest, arms.)

Wrap Material

- **Patient side:** Non-Woven Polypropylene
- **Exterior:** Brushed Loop Fabric

Usage Duration

The wrap is durable for up to 120 hours. Replace the wrap if it becomes soiled.

Risk of Reuse

CureWrap is for single use only. Reuse could lead to cross-contamination and/or irritation.

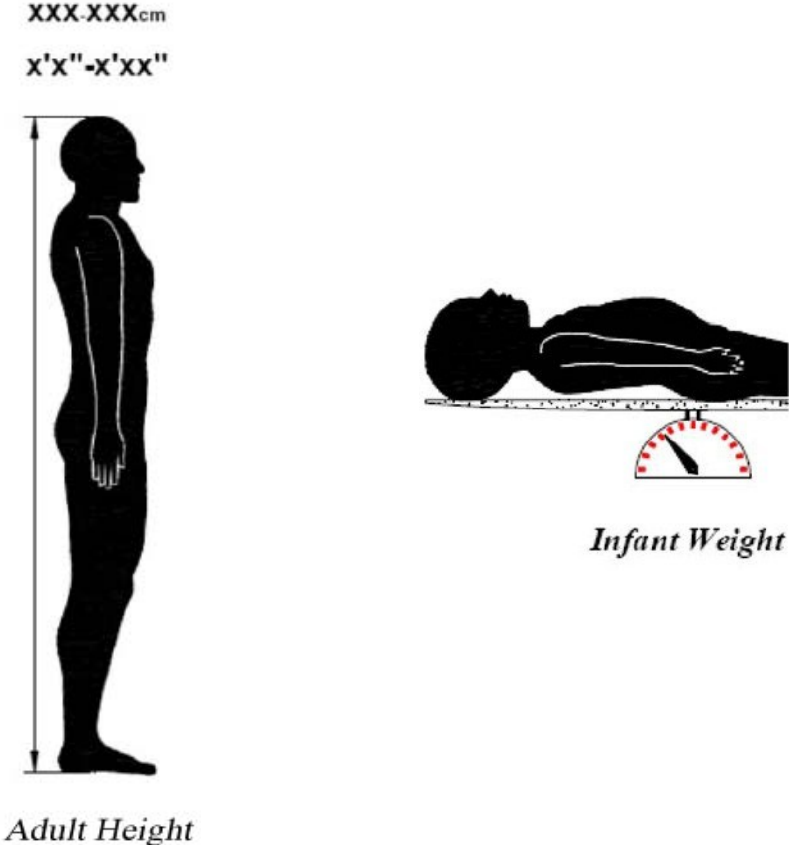

Figure 5: Measurements

Selected Wrap Design

The wraps are available in a range of sizes and are based on patient size and weight. Use a size up if deciding between two sizes.

Table 2: CureWrap®

	Type	Box Part Number	Wrap Single Part Number and Quantity per Box	Patient Size/Weight	Wrap Height/Width (m)
CureWrap Single Size Pediatric Boxes	Infant	508-03518	500-03518 (X8)	2.5-4 Kg	0.659 / 0.448
		508-03521	500-03521 (X8)	4-7 Kg	0.698 / 0.602
CureWrap Assorted Pediatric Boxes	Small	PED-SM008	500-03518 (X4)	2.5- 4 Kg	0.659 / 0.448
			500-03521 (X4)	4-7 Kg	0.698 / 0.602
	Medium	PED-MD008	500-03525 (X4)	7-11 Kg	0.981 / 0.628
			500-03531 (X4)	79-91 cm	1.118 / 0.740
Large	PED-LA008	500-03536 (X4)	91-104 cm	1.225 / 0.841	
		500-03541 (X4)	104-122 cm	1.390 / 1.054	
X-Large	PED-XL008	500-03548 (X4)	122-135 cm	1.582 / 1.1193	
		500-03500 (X4)	Over 135 cm	2.030 / 1.354	
CureWrap Single Size Adult Boxes	Adult	508-03500	500-03500 (X8)	Over 135 cm	2.030 / 1.354

Accessories

The following accessories are available for use in conjunction with the CritiCool® system.

Temperature Probes

Intended Use

Core temperature probes are used to measure the patient's core temperature.

Surface temperature probes are used to measure the patient's skin temperature, in a location not covered by the wrap.

Disposable temperature probes are recommended.

CAUTION! *Before use, check the packaging and expiration date of the temperature probes. If the package is not completely sealed or the temperature probes are past the expiration date, avoid using the temperature probes.*

NOTE: *The response time for temperature feedback to the CritiCool device for all temperature probes once plugged in and attached to the patient is less than 60 seconds.*

Reusable Temperature Probes

There are three color-coded reusable temperature probes: Adult Core 12 FR (gray), Surface (green), and Infant Core 10 FR (gray), and Surface (green). Both core and surface probes must be plugged into the CritiCool® system. The core temperature probes must be inserted, and the surface temperature probe must be attached to the patient for the system to function properly.

CAUTION! *The cleaning, disinfection and the sterilization of the reusable temperature probes are done in accordance with the manufacturer's directions. Refer to the manufacturer's user guide for details of applicable usage.*

1.1. 12 FR Adult Core Temperature Probe:

The core temperature probe (gray 12FR) measures core body temperature when inserted into the patient's body. The plug of the probe cable is inserted into the gray core socket at the front of the CritiCool® device.

1.2. 10 FR Infant Core Temperature Probe:

The core temperature probe (gray 10FR) measures core body temperature when inserted into the patient's body. The plug of the probe cable is inserted into the gray core socket at the front of the CritiCool® device.

1.3. Surface Temperature Probe:

The surface temperature probe (green) measures body surface temperature when attached to the patient's skin. The plug of the probe cable is inserted into the green surface socket at the front of the CritiCool® device.

Disposable Temperature Probes

Disposable temperature probes are attached to two color-coded adapters: gray (Core) and green (Surface). Both adaptors are reusable. For the system to function properly, the core temperature probe must be inserted into the patient and the surface temperature probe must be attached to the patient’s skin.



CAUTION! *Before use, please check the packaging and expiration date of the disposable temperature probes. If the package seal is not intact or the probes have expired, do not use. Review the instructions for use and contraindications for the probes prior to use.*

1.1. Disposable Core Temperature Probe:

The disposable core temperature probe is attached to the reusable core adapter (gray). The adapter is plugged into the gray core socket at the front of the CritiCool® device. The temperature probe is inserted into the patient (esophagus/rectum) and measures core body temperature.

See [Figure 6](#) for images or [Table 3](#) for ordering information.

Figure 6: Disposable Core Temperature Probe Connection

Reusable Adapter Cable	Compatible Disposable Temperature Probes
<p data-bbox="212 1094 418 1125">PN# 014-00028</p> 	<p data-bbox="849 1094 1055 1125">PN# 014-00035</p> <p data-bbox="849 1144 1055 1176">PN# 014-00036</p> <p data-bbox="849 1194 1055 1226">PN# 014-00220</p> <p data-bbox="849 1245 1055 1276">PN# 014-00038</p> 

1.2. Disposable Surface Temperature Probe:

The disposable surface temperature probe is attached to the reusable surface adapter (green). The adapter is plugged into the green surface socket at the front of the CritiCool® device. The temperature probe is attached to the patient’s skin and measures surface body temperature.

See [Figure 7](#) for images or [Table 3](#) for ordering information.

Figure 7: Disposable Surface Temperature Probe Connection

Reusable Adapter Cable	Compatible Disposable Temperature Probes
<p>PN# 014-00324</p> 	<p>PN# 014-00323</p> 

Table 3: Part Numbers: Disposable Temperature Probes and Associated Cables

Part number	Description
Core	
014-00028	Adaptor Cable for Disposable Core Temperature Probes, Gray
014-00035	Disposable Core Temperature Probe, 9 Fr, Smiths Medical ER400-9 (20/pack)
014-00036	Disposable Core Temperature Probe, 7 Fr, Metko FMT400/AOR-D2 (40/pack), OUTSIDE USA ONLY
014-00220	Disposable Core Temperature Probe, 9 Fr, DeRoyal 81-020409 (50/pack), USA ONLY
014-00038	Disposable Core Temperature Probe, 9 Fr, TE Measurement Specialties 4491 (20/pack), USA ONLY
Surface	
014-00324	Adaptor Cable for Disposable Surface Temperature Probes, 3.5 mm (1/8") Mono Jack, Green
014-00323	Disposable Surface Temperature Probes, 3.5 mm (1/8") Mono Jack (50/pack)
014-00221	Disposable Surface Temperature Probes, YSI 400, DeRoyal (50/pack), USA ONLY

Detachable Electric Power Cable & Plug

Use the power cord to power the system.

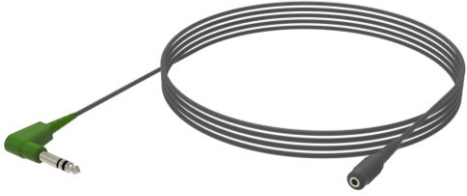
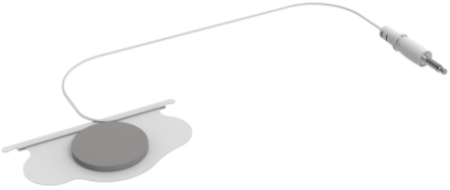
Connecting Tubes for Wrap

Two flexible 2.58 m long connecting tubes connect the wrap with the CritiCool® device to

enable the flow of water between them.

The tubes are supplied as a paired unit with two male Quick Coupling Connectors for the CritiCool® device and with two or three female Quick Coupling Connectors for the Wrap.

Male Connector for Draining Water Tank

The male connector is attached to the connecting tubes and is used to drain the water tank. It connects to the outflow hose of the Quick Coupling Connector of the Connecting Tubes.

Spare Water Filter

The spare water filter is used by a trained biomedical technician for annual filter replacement.

Handle

A handle is shipped with every system and should be attached to the device to facilitate intra-hospital transport.

CliniLogger™ (Optional)

CliniLogger™ is used to collect the system parameters during the thermoregulation procedure. It can only collect data when connected to CritiCool. It connects to the serial port on the rear of the device either vertically with the grey right angle adapter attached at the bottom, or horizontally, with the adapter removed.

For instructions for use on using CliniLogger and analyzing the data, visit the Belmont website at www.belmontmedtech.com/resources.

Temperature Splitter (Optional)

The Temperature Splitter is compatible for the CritiCool® system using the YSI 400 Series temperature probes. The Temperature Splitter measures the patient's temperature using a single sensor in the patient and displays the temperature on both the CritiCool® screen and an additional system, such as a monitor, eliminating the need to use two separate sensors. See the diagram.

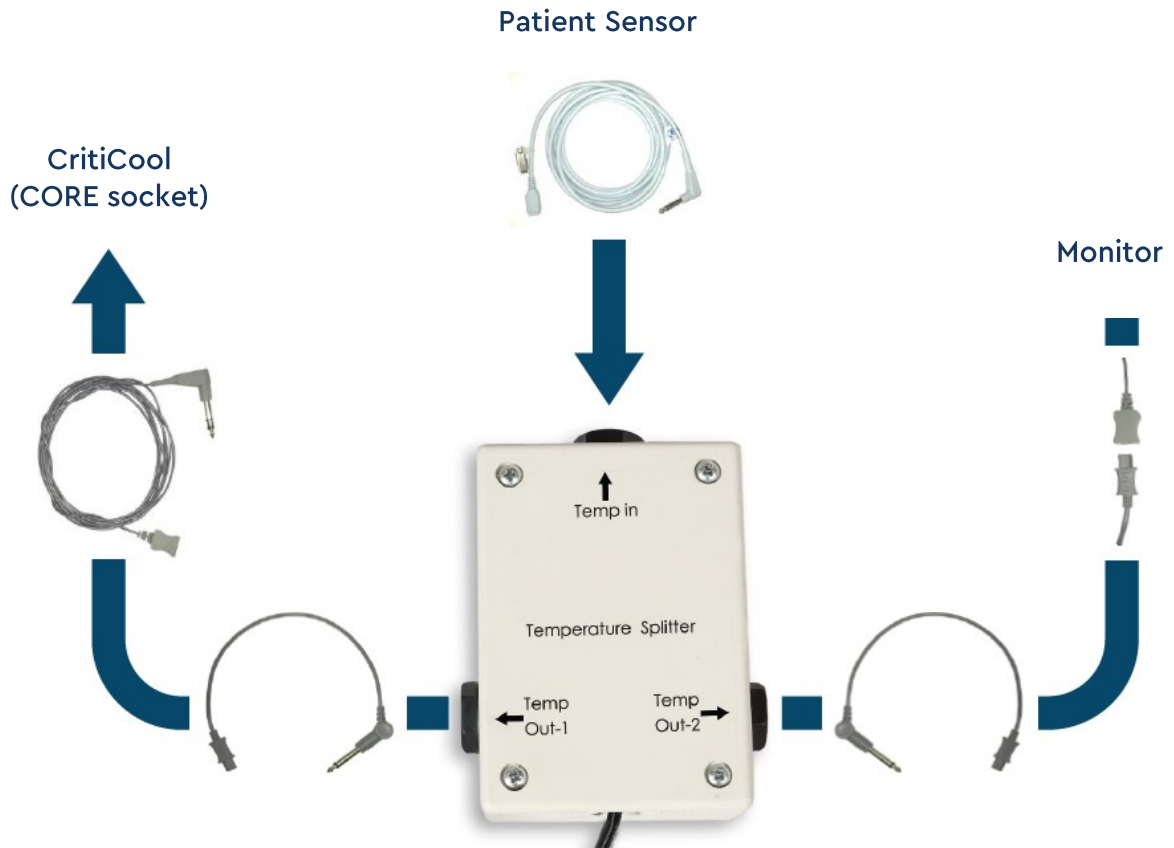

System Specifications

See the following page for system specifications.

CritiCool® Technical Specifications

CritiCool®

CritiCool®, one of Belmont Medical Technologies' temperature regulating systems, induces, maintains and reverses hypothermia in an effective and precise manner. The desired patient temperature is preset by the physician with a possible range of target temperature from mild hypothermia to normothermia.

The system is composed of two elements, the CritiCool device and the CureWrap® garment. The CritiCool® device functions as a control unit, constantly monitoring the patient's core temperature every 133 milliseconds, and as a cooling/heating device which brings the circulating water to the required temperature by using its on-board body temperature control algorithm. The CureWrap® is a flexible 3D single-piece garment through which water circulates. It is designed to be in close contact with a large area of the body to optimize energy transfer.

Control Unit

Physical Dimensions	Mobile Unit with 4 wheels and 2 brakes 260 mm W x 625 mm D x 940 mm H (10.23" W x 24.6" D x 37"H)
Net Weight	36 kg / 79 lb
Environmental Operating Conditions	
Temperature	5°C to 40°C (41-104°F)
Humidity	10 to 93%, non-condensing
Note:	Not intended to be used in an oxygen rich environment. Do not use in an atmosphere with flammable anesthetic mixtures.
Environmental Storage Conditions	
Temperature	-15°C to +68°C (5-154°F)
Humidity	10 to 93%, non-condensing
Service Life	7 years
Hardware	
Electricity Input Power	230/115 VAC (Switchable) with isolation transformer 50/60 Hz 100 VAC with isolation transformer 50/60 Hz
Maximum Power Consumption	690 Watts 230 VAC 2.9A 115 VAC 5.7A 100 VAC 6.6A
Heat Exchangers	Peltier Technology – Thermoelectric Coolers (TECs)

External Ports	(1) Isolated Serial Port
LCD Display Size	144.8mm / 5.7" color display
LCD Display Resolution	320x240
User Interface	Multicapacitive Touch Screen 5 soft push buttons
System Sensors	3 Internal Temperature Sensors: 1) Water In, 2) Water Out, and 3) Thermostat 2 Pressure Sensors
Water	
Water Type:	Sterile or 0.22 µm filtered water
Tank Capacity:	6 liters (1.6 gallon)
Pump Rate:	1.2 L/minute
Water Temperature Accuracy:	±0.3°C
Water Temperature (Outflow) Range:	13-40.8°C (55.4-105.4°F)
Patient Temperature	
Patient Temperature Channels	2 channels: 1) Core and 2) Surface
Patient Temperature Probe Accuracy	±0.3°C
Software	
Modes of Operation (continuous)	TTM (Targeted Temperature Management) Controlled Rewarming Normothermia Standby (No thermoregulation; monitoring only)
Patient Set Point Temperature	
Target Temperature Range	30-40°C (adjustable in 0.1°C increments)
TTM Mode Default Set Points	Neonatal Mode : 33.5°C Adult Mode : 33.0°C
Controlled Rewarming Default Target Temp	36.5°C
Controlled Rewarming Default Rate Range	0.05°C – 0.5°C per hour
Manual Rewarming Rate	Adjustable in 0.1°C increments
Adjustable Alarm Limits	High Patient Temperature Low Patient Temperature High Water Temperature

Displayed Information	Mode of Operation Care Time System Status and Alarms Patient Set Point Temperature Patient Target Temperature Patient Core Temperature Patient Surface Temperature Temperature Graph Technician Mode and Display
Languages	
<ul style="list-style-type: none"> • English (EN) • Czech (CS) • Danish (DA) • Dutch (NL) • Finnish (FI) 	<ul style="list-style-type: none"> • French (FR) • German (DE) • Italian (IT) • Norwegian (NO) • Polish (PL)
	<ul style="list-style-type: none"> • Portuguese (PT) • Russian (RU) • Spanish (ES) • Swedish (SV) • Turkish (TR)
CureWrap®	
Range of Sizes	44 cm – 200 cm
Duration of Use	up to 120 hours unless soiled
Wrap Storage	
Storage Span	5 years
Temperature Conditions	10°C to 27°C
Humidity Conditions	10-90%
Wrap Transport	
Temperature Conditions	-20°C to 60°C
Humidity Conditions	20-95%

CliniLogger™ Technical Specifications

CliniLogger™

CliniLogger™ is an optional accessory for CritiCool® / CritiCool® MINI / Allon® Thermoregulation Systems. It is used to collect the system parameters during the thermoregulation procedure.

CliniLogger™ must be connected to the serial port on the rear of the device to collect data. It can be connected vertically with the grey right-angle adapter attached at the bottom (as shown at the right), or horizontally once the adapter has been removed.

For instructions for use on using CliniLogger™ and analyzing the data, visit the Belmont website at www.belmontmedtech.com/resources.



Hardware

Connector	DB9 connector for serial interfacing to CritiCool® or general PC
Size	35 x 65 mm
Controller	MSP4301611 Micro controller with the following features: Built in Flash and RAM Built in UART & SPI Built in DMA controller
Memory	Flash memory capacity: 2 MB
Power Requirement	5 Volt DC supplied from the CritiCool® or general PC <20 mA <100 mW
LED	Bicolor (Green / Red)
Data Storage Rate	Every 1 minute into flash memory
Serial Communication	RS232: 19200 bps to CritiCool® 115200 bps to PC
Data Collected	Temperature: Set Point, Core, Surface Time Water Circulation ON/OFF Water Heat/Cool Mode of Operation Errors
PC Application	CliniViewer Software

Chapter 3: Installation

Pre-installation Requirements

Space and Environmental Requirements

The CritiCool® system is supplied on a trolley as a mobile unit for user convenience. It must be located no less than 5 cm (2") from other objects to avoid the impairing of ventilation to the CritiCool® system. Further, to avoid electromagnetic interferences, it should be no less than 30 cm (11.8") from equipment emitting electromagnetic frequencies. (See page 127).

The following dimensions should be considered when placing the CritiCool® system:
260 mm W x 625 mm D x 940 mm H / (10.23"W x 24.6"D x 37"H)

Electrical Requirements

230/115VAC 500W or 100 VAC

WARNING! *To avoid the risk of electric shock, this equipment must only be connected to a mains supply with protective earth (PE).*

CAUTION! *Verify that the voltage switch is set for the local voltage.*

Equipment List

The CritiCool® system includes the following:

- CritiCool® control unit
- Handle
- Power cord
- Spare filter
- User manual
- Quick reference guide
- Accessories Kit for CritiCool® – one of the following (See Table 6 through Table 9):
 - 200-00300 Accessory Kit Adult with Reusable Temperature Probes
 - 200-00310 Accessory Kit Adult for Disposable Temperature Probes
 - 200-00320 Accessory Kit Infant with Reusable Temperature Probes
 - 200-00330 Accessory Kit Infant for Disposable Temperature Probes

Unpacking and Inspection

The CritiCool® system has undergone full quality assurance testing before shipment and should be operational upon delivery.

The unit should be unpacked, installed and tested only by Belmont Medical Technologies authorized personnel. No attempt should be made by the purchaser to unpack or assemble the unit alone.

NOTE: Report any container damage prior to opening the container, or any unit damage prior to unpacking, installation, or testing to your Belmont Medical Technologies distributor.

Unpacking CritiCool from the Box

Follow the instructions shown here to properly unpack CritiCool. Be sure to keep the packaging.

Upon arrival, check the SHOCKWATCH® and TIP-N-TELL® indicators.

If either has been activated, immediately open the package and check for external damage. If the device has been damaged, photograph the damage and immediately notify the shipping carrier and/or Belmont Medical Technologies at techservice@belmontmedtech.com, being sure to provide all relevant information, including evidence of the damage.

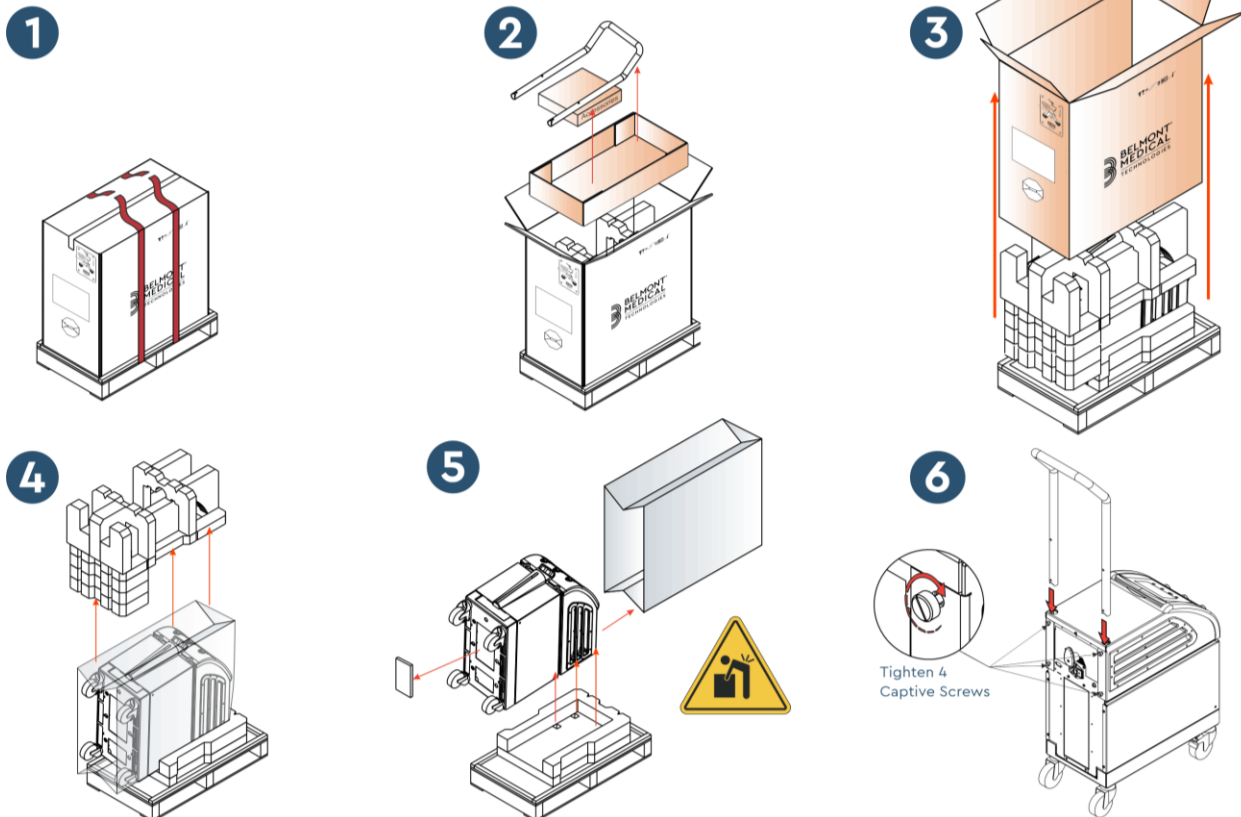

Assembling the Handle

To assemble the handle:

1. Release the four thumb screws by hand.
2. Slide the two ends of the handle into the holes in the top cover (pay attention to the direction of the curve in the handle) until the handle is inserted all the way in (See [Figure 8](#)).
3. Press in and screw the four thumb screws by hand (do not use force when tightening) to secure the handle and the top cover.

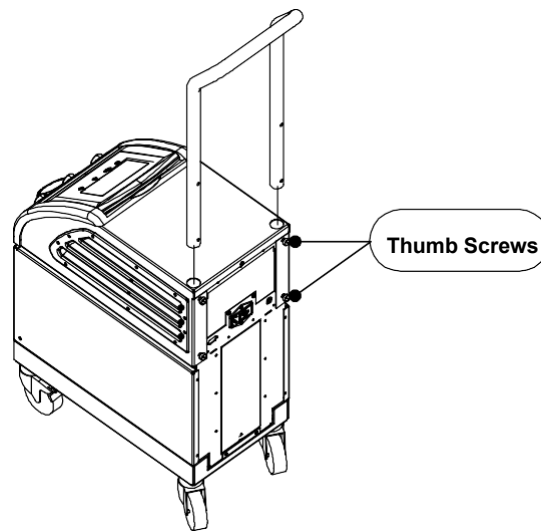

Figure 8: Handle Assembly

Moving the Unit

Preparation:

Before moving the unit:

1. Ensure that the CritiCool® system is off by pressing the ON / OFF switch.
2. Ensure that all electrical connections are disconnected.

Locking and Unlocking the Trolley Wheels

The CritiCool® device trolley has four wheels. The front wheels are fitted with a brake. The brake lever is located over the wheel. To lock the wheels, firmly press the lever. To release the wheels, lift the lever.

When the unit is stationary, the brakes must be in the locked position. Release the brakes only when transporting the unit.

Packing CritiCool for Shipment

Please follow these instructions to properly prepare CritiCool for transport. Empty the water tank prior to packing CritiCool.

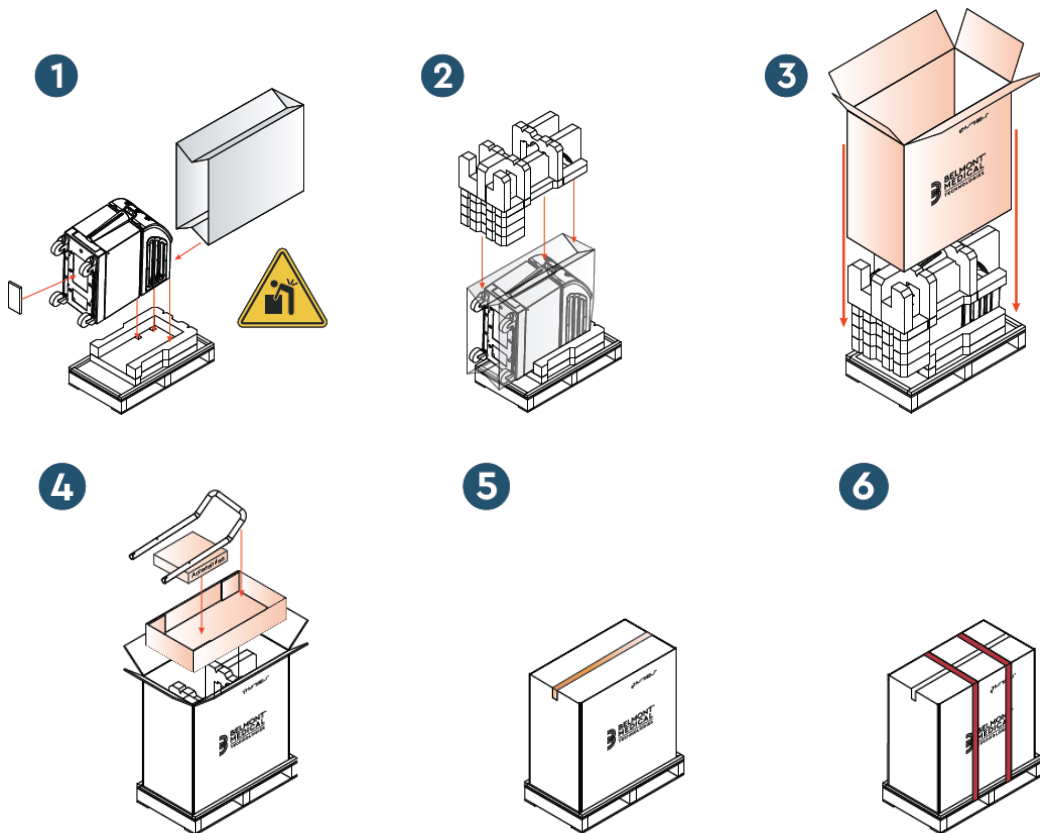

Chapter 4: Operating Instructions

General

This chapter contains:

- A description of the controls, indicators and connections for the CritiCool® system
- Detailed operating instructions for the CritiCool® system for the different modes of operation.

CritiCool Functions

CritiCool® is used for patient thermoregulation.

Patient thermoregulation includes the following operation modes:

- TTM: Targeted Temperature Management
- Controlled Rewarming: Slow rewarming
- Normothermia

CritiCool starts up in one of two patient modes, Adult or Neonatal, depending on the chosen settings. The default settings are different for these two modes. Both can be set by the user per the protocol used at each hospital. The user should set the appropriate patient mode in Settings when setting up the machine. See page 49 for further instructions.

CureWraps are available to fit patients of varied size and weight.

Controls, Functions, Indicators and Connections

Main Power Switch





The main power switch, located at the rear of the unit, switches the CritiCool® system ON and OFF.

The self-test panel is displayed (See page 42). At the end of the Self-Test, an alarm is automatically activated.

CritiCool® Screen Controls

The CritiCool® screen is a touch screen, with additional hard keys to the right of the panel:

Table 4: CritiCool® screen keys

<i>Icon</i>	<i>Description</i>
	Main Menu and Escape
	Show Graph / Change Graph Parameters
	Alarm Tone ON/OFF
	Open Setting Panel / Change Setting
	Accept Change

NOTE: *The alarm icon is an informative icon only. To silence an alarm, the user must press the hard key of the alarm, located to the right of the panel.*

QCC— Quick Coupling Connectors

The Quick Coupling Connectors are located at the front of the CritiCool® device (see circles below) and are connected to the Wrap by the connecting tubes.



There are two Quick Coupling Connectors below the Core and Surface Temperature Probe Sockets:

- Water Out Quick Coupling Connector on the right (gray)
- The Water In Quick Coupling Connector on the left (green)

Temperature Probe Sockets

There are two temperature probe sockets located at the front of the CritiCool® device above the Quick Coupling Connectors:

- Core – for the core temperature probe or adapter cable (gray)
- Surface – for the surface temperature probe or adapter cable (green)

Patient Thermoregulation – Step by Step Operation

NOTE: *Ambient temperature and other environmental factors can affect thermoregulation with CritiCool. Other devices used with the patient as well as room temperature may need to be adjusted to reduce the impact on thermoregulation with CritiCool.*

1. To prepare the system for operation:
2. If the user wishes to record procedural data, connect CliniLogger to the RS-232 port on the back of the device. The CliniLogger is explained on page 33 and the RS-232 port is shown in [Figure 4 on page 21](#).
3. In an area away from patient care, remove the water tank feeder cover and pour in sterile water until the water level reaches the first red line. The tank holds six liters of water.

NOTE: *Sterile water is recommended. 0.22 micron filtered tap water may also be used.*

4. Observe the water-level indicator to prevent overfilling the water tank. Close the water tank feeder cover.

NOTE: *In case of overfilling, see page 103.*

5. Place the unit in the desired position according to Space and Environmental Requirements on page 34.
6. Press the brake pedals and lock the wheels to secure the CritiCool® device.
7. Connect the CritiCool® device to the power source.

Operating the System

To turn on the system:

1. Turn the main power switch upwards to the ON position. The Self-Test panel is displayed (see Figure 9). At the end of the Self-Test, the alarm is automatically activated.

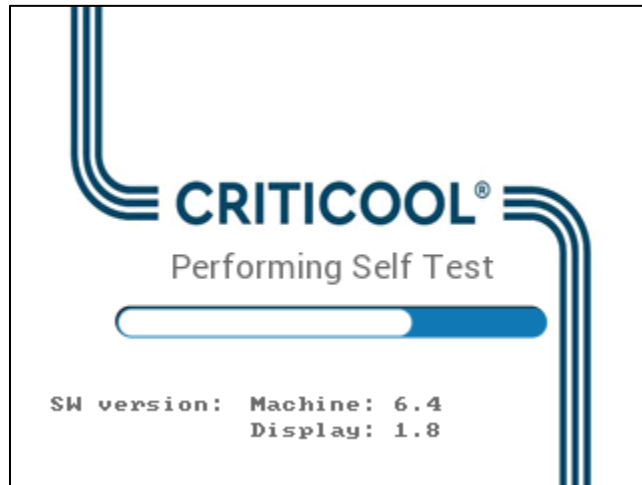

Figure 9: Self-Test Screen

NOTE: The CritiCool® system is equipped with self-testing routines that continuously monitor system operation.

NOTE: The Self-Test will occur only if the CritiCool® system has been shut off for at least ten minutes. If you wish to use the system after it has been shut off for less than ten minutes, the system will start up in the last screen it was in. The Self-Test will not be initiated, and you will need to use the Menu button to navigate to the preferred mode of operation or desired screen.

2. If the Self-Test discovers a condition that may impact operation, a Halt Error will occur. Halt 4 is shown below as an example.



Figure 10: Halt Error

- In this case, turn off the system, wait at least ten minutes, and then power on the system. If the halt error reappears upon startup, the system should be evaluated by a Belmont trained biomedical technician, and the name of the error provided (“Halt 4”, in the above example).
 - The Service Manual includes more troubleshooting information for Halt errors.
3. Following a successful Self-Test, the system automatically starts to cool the water through internal circulation (as in Standby Mode).

NOTE: *When using CritiCool to warm a patient or maintain normothermia, it is highly recommended to fully set up CritiCool and the patient probes before turning on CritiCool® to prevent the water from cooling upon powering.*

NOTE: *When using CritiCool to lower patient temperature, it is highly recommended to let the CritiCool® run before connecting temperature probes and hoses to allow the water to cool.*

4. Select the appropriate wrap, remove it from the package and place it on the bed or underneath the patient. (See [Table 2: CureWrap®](#)).

NOTE: *Do not wrap the patient at this time. The Wrap should not be fastened around the patient until it has filled with water.*

Connecting the Water Hoses (Tubes) to CritiCool

Select the corresponding connecting water tubes according to the Wrap in use.

2x3 Way Connecting Tubes (Part Number 200-00147) will be needed for CureWrap® model 500-03500 which is sold in PED-XL008 and 508-03500. All other CureWraps will require 2x2 Way Connecting Tubes (Part Number 200-00109).

The Quick Coupling Connectors (QCC) are located at the front of the CritiCool® device. See page 40.

To connect the connecting tubes:

1. Lock the connecting tubes by pressing the metal ends of the tubes (see below) into each Quick Coupling Connector on the device; when locked, a clicking sound is produced.

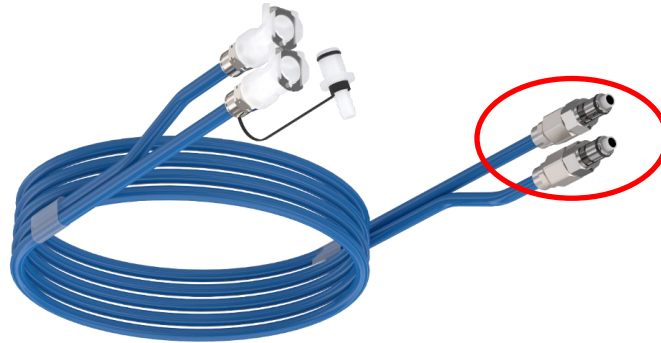

- a. If the tubes feature color coding, match the colors (green to green on the left, Water Inside and gray to gray on the right, Water Outside).
 - b. If the tubes do not feature color coding, either end may be connected to either end. However, later, when it comes time to empty, the connections may need to be reversed to successfully drain from Water Out.
2. Verify that the tubes are locked by lightly tugging them towards you.
 3. Connect water tubes to the wrap and to CritiCool, listening for a click upon each connection. Open the clamps on the wrap, if necessary.

NOTE: If the tubes are not properly connected to the device, or the clamps to the wrap are closed, water will not flow to the wrap, and, if a mode has already been selected, you will notice the disappearance of the OK symbol in the top left corner of the screen.

To disconnect the tubes:

- Press the metal flange and pull out each connecting tube.

WARNING!! *Water may drip from the inlet tubes of the wraps. Be sure that no electrical device or outlet is located under the CritiCool's® water inlet or wrap tubes. When disconnecting wraps from the CritiCool®, confirm that the clamps are tight to prevent water leaking from the wrap.*

Inserting and Attaching Temperature probes

WARNING! *For proper use of the CritiCool® system, the core temperature probe must be inserted, and the surface temperature probe must be attached to the patient per the probes' instructions for use. The location of the surface temperature probe is a clinical decision. All temperature probes directly measure temperature.*

1. Insert the core temperature probe or gray adaptor cable (reusable or disposable) into the right socket labeled "CORE" color-coded with gray on the front of the device. (See [Figure 2 on page 19](#)).
2. Insert the core temperature probe (reusable or disposable) into the patient's rectum or esophagus.

CAUTION! *The CritiCool® system does not initiate thermoregulation if the core probe is not properly inserted into the patient. Ensure that direct patient feedback is monitored at all times.*

NOTE: *Confirm that the core (not the surface) probe is connected to the cable plugged into the CORE socket, or if using a reusable probe, directly into the CORE socket.*

3. Insert the surface temperature probe or green adaptor cable (reusable or disposable) into the left socket labeled "SURFACE" color-coded with green on the front of the device.
4. Attach the surface temperature probe (reusable or disposable) to an exposed area of skin with adhesive tape. When the patient is wrapped, the surface temperature probe should not be under the CureWrap® or covered.

NOTES:

- The disposable temperature probes need to be connected to an adapter. Make sure to connect the appropriate probe to its adapter (note the labeling on the adapter).
- Be sure to read and follow the instructions for use of the temperature probes being used, paying particular attention to indications and contraindications.
- Regarding core and surface adapter cables PN# 014-00028 and PN# 014-00324 specifically:
 - Carefully inspect the adaptor cable before use
 - Ensure correct fit
 - Use with 400 series medical electronics
 - Wait for the probe temperature to stabilize

- Route the adaptor cable carefully to avoid patient entanglement and strangulation
- Do not damage or modify adaptor cables
- Do not boil or autoclave

Activating the System

After the Self-Test, the Select Mode screen appears with Targeted Temperature Management (TTM) mode highlighted.

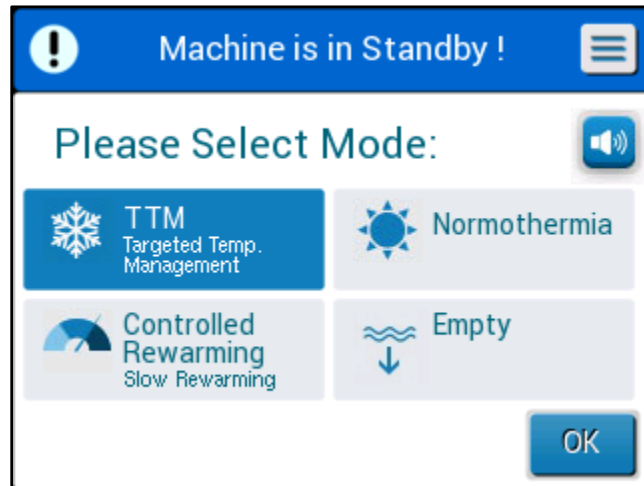

Figure 11: Mode Select Upon Startup

While this screen is displayed, the water temperature circulating within the system will continue to cool.

Touch the required mode, then touch **OK**.

The Thermoregulation Main Screen Control Panel appears, and because all connections have been made, the wrap will begin to fill. The algorithm-derived goal temperature of the water will now be calculated based on the patient temperature and Set Point.

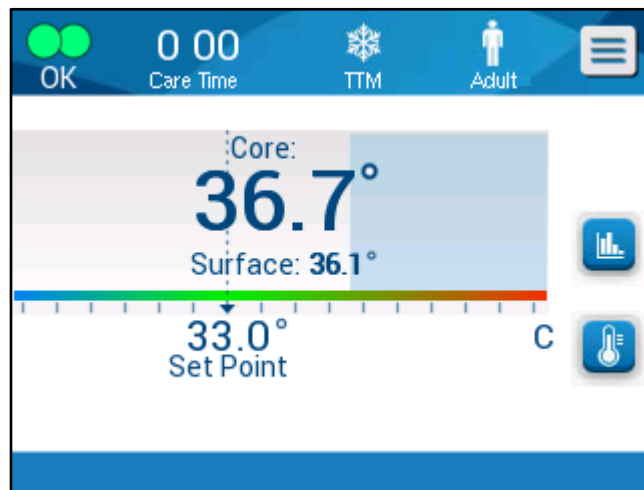

Figure 12: Main Screen

Once CritiCool® is turned on, all operating functions are controlled by the LCD Touch Screen. Alternatively, the control panel's hard keys and visual displays guide you through each operational phase as well.

The CritiCool® system is now operational and preparing itself for the start of therapeutic treatment.

NOTE: Confirm that the Patient Mode shown to the left of the Menu button indicates the desired Patient Mode (either **Adult** or **Neonatal**). If it needs to be changed, change the mode in Settings; refer to page 49 or further instruction.

Confirm that the Set Point is set appropriately. If needed, adjust using the



Set Point Key.

Wrapping the Patient

After the desired mode has been chosen and water has filled the wrap, the CureWrap can be positioned around the patient. Follow the CureWrap Instructions for Use pamphlet DLW136003 when wrapping the patient, being careful to keep a finger's breadth between the patient and the wrap.

NOTE: Before securing the wrap to the patient with the Velcro strips, confirm that the wrap has filled with water.

NOTE: If the wrap is soiled, replace the wrap.

The Control Panel

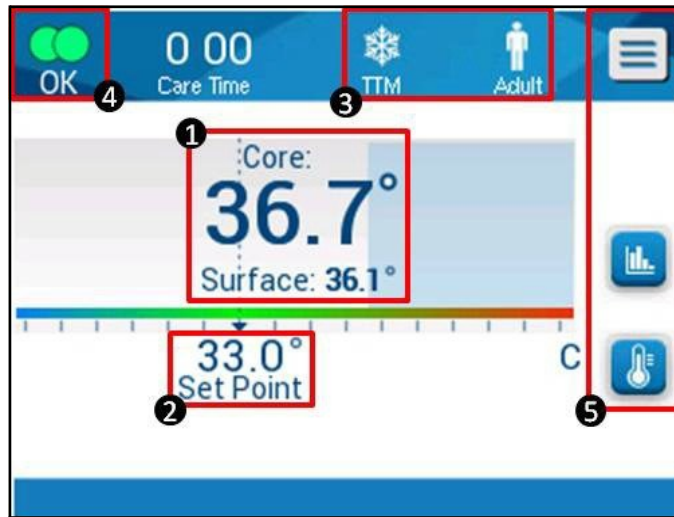







Figure 13: The Control Panel

The Control panel displays the following:

- Patient Core and Surface Temperatures ①
- Set Point Temperature ②
- CritiCool® Mode and Patient Mode ③
- **OK** indicator to indicate that water is flowing into the wrap and the system is functioning correctly ④
- Action Icons and Touch keys ⑤
- Menu  / Escape 
- Alarm ON 

NOTE: The Alarm icon appears only if there is an Alarm condition. This icon is informative only and not an action button (It is not a touch button).

- Graphical Display of CritiCool® Parameters 
- Set Point / Target Temperature Control 

Patient Mode

The Patient Mode affects alarm conditions as well as the default set point.

Patient Mode is designated by one of two icons:

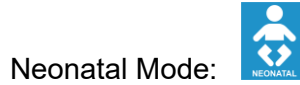

To adjust the Patient Mode, press **Menu** . A list of options appears.

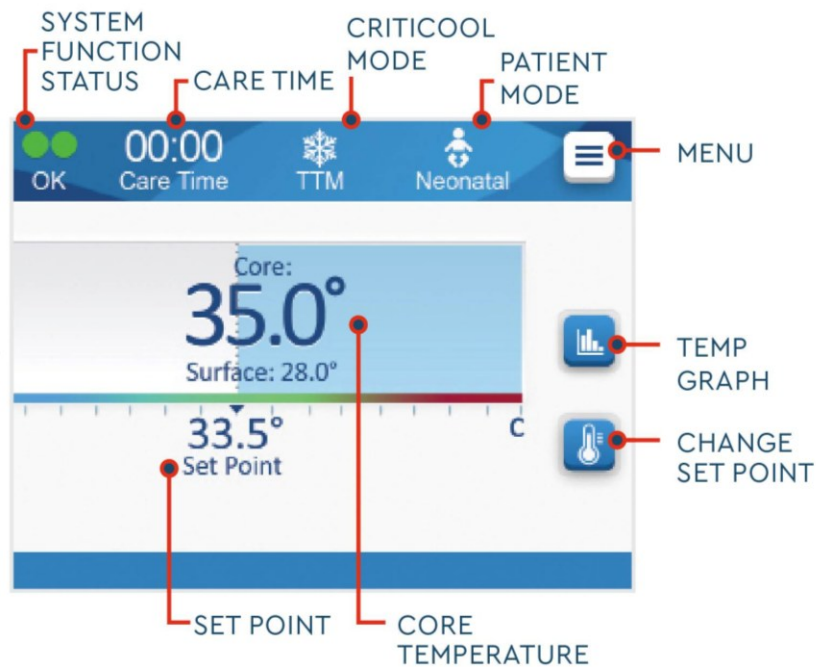

Press **Settings**. You will be asked to enter the passcode, which can be found in the manual under Settings on page 58. Enter the code and then press **OK**.

Settings Screen 1 will appear (see below).

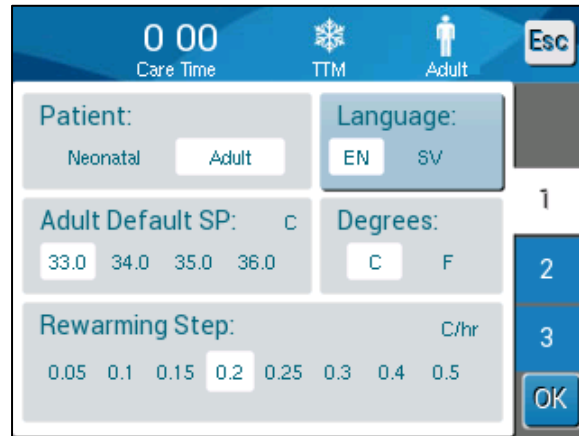

Figure 14: Settings Screen 1

Patient Mode is displayed in the top left section titled “Patient”. The selected Patient Mode is highlighted with a white box. In this scenario, Adult Mode is selected.

To select a different mode, press the desired Patient Mode, either **Neonatal** or **Adult**. The new Patient Mode will now be highlighted with a white box. Press **OK** to finalize the change.

NOTE: The Neonatal and Adult modes have different settings during operation.

The Main Screen will now show the new Patient Mode icon.

A message “Patient Mode Changed. Check Set Point” will appear and remain on the screen for 30 seconds (Software version 6.4 only).

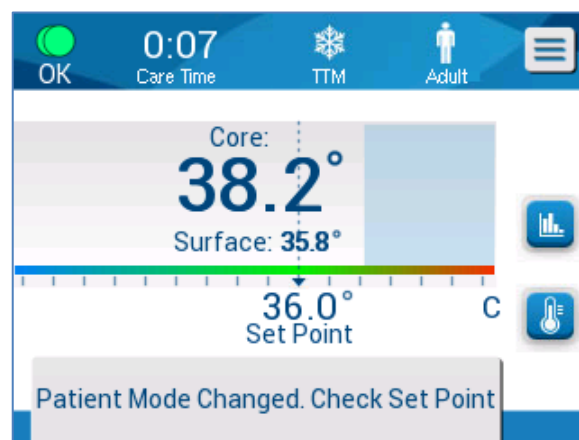

Figure 15: Patient Mode Changed. Check Set Point

The set point should always be confirmed after changing the patient mode.

Neonatal Mode (TTM Mode)



The Neonatal Mode is designated by this icon:

Neonatal Mode in TTM Mode has a default Set Point (SP) Temperature of 33.5°C (92.3°F).

If required by clinical protocol, change the Set Point by using the Set Point key on the Main Screen: See page 64 for more detail.

NOTE: *If the machine is shut off and a time lapse of ten minutes or more occurs, the set point will return to the factory setting of 33.5°C for TTM in Neonatal Mode.*

In Neonatal Mode, when the message “Core Readout Too Low” appears, thermoregulation is paused, and water stops flowing to the wrap.



See page 107 for more details.

Adult Mode (TTM Mode)



The Adult Mode is designated by this icon:

Adult Mode in TTM Mode has a default Set Point (SP) Temperature of 33.0°C (91.4°F).

If required, change the Set Point by using the Set Point key on the Main Screen (see right).



NOTE: *If the machine is shut off and a time lapse of ten minutes or more occurs, the set point will return to the selected default setting for TTM in Adult Mode, labeled as “Adult Default SP”.*

The default set point temperature for adult mode in TTM mode can be changed and will be the new set point in Adult Mode upon restarting. To change the selection, press **Settings**. You will be asked to enter the passcode, which can be found in the manual under Settings on page 58. Enter the code and then press **OK**.

Settings Screen 1 will appear.

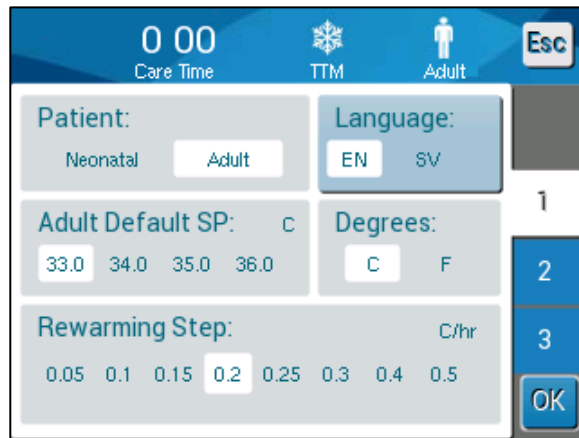

Adult Set Point is displayed in the top left section below “Patient”, and it is titled “Adult Default SP”. The selected default set point for Adult Mode is highlighted with a white box. On the screen shown, 33.0 is selected.

To select a different default set point for Adult Mode, press one of the other default set point options.

Options for Adult Default Set Point (Adult Default SP) include:

- 33.0°C
- 34.0°C
- 35.0°C
- 36.0°C

The new chosen Adult Default Set Point will now be shown in a white box.

Press **OK** to finalize the change.

The Main Screen will now display the new Adult Default Set Point.

In Adult Mode, when the message “Core Readout Too Low” appears, thermoregulation is paused, but water continues flowing to the wrap unless patient Core Temperature is below 30.8°C.

NOTE: *Adult Mode triggers different responses than Neonatal Mode.*

See page [107](#) for more details.

The Main Menu

When you touch the Menu icon , a list of options appears.

The options include the following:

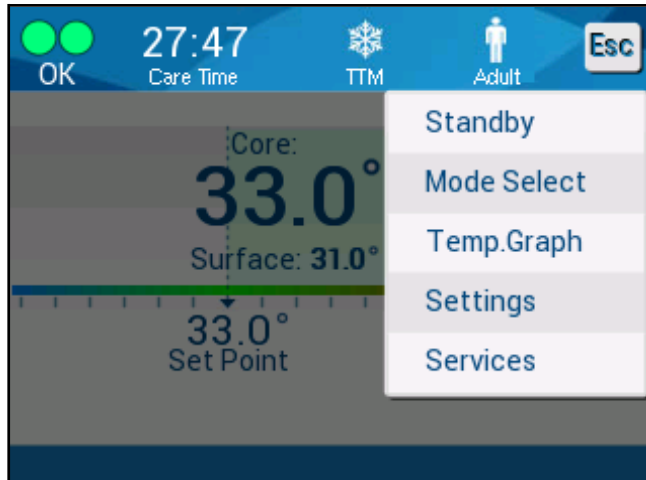

Figure 16: Main Menu

- Standby
- Mode Select
- Temp Graph
- Settings
- Services

Standby Mode

Use Standby mode in instances when the circulation of water to the wrap is temporarily required to stop. It is recommended to put the system in Standby prior to shutting it off.

In this mode, there is neither external water circulation nor thermoregulation. The CritiCool® system keeps monitoring patient temperatures and circulating the water internally.

NOTE: *No alarms will occur when the system is left in Standby Mode. Because no thermoregulation occurs in this mode, if a patient is left in Standby Mode for extended periods of time, the patient may become too warm or cold. It is important for the patient to be monitored by the clinical team during all phases of treatment, including when CritiCool is in Standby Mode.*

To go to Standby:

1. Touch the MENU icon .
2. Touch Standby

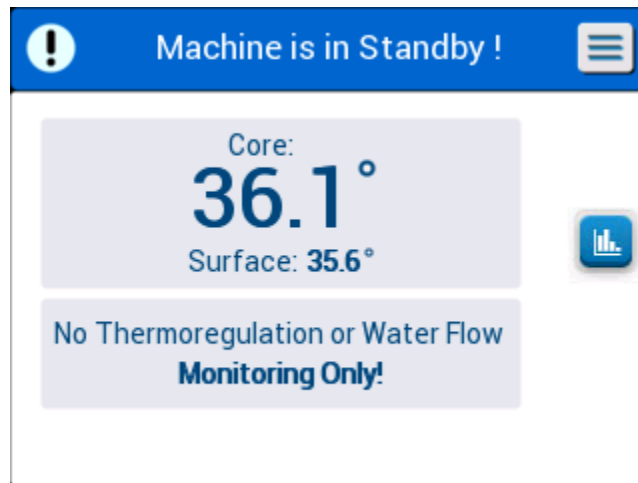

Figure 17: Standby Mode

Mode Select

The MODE SELECT panel enables selecting a mode of operation or re-initiating a mode.

To select a mode:

1. Touch the MENU icon .
2. Touch **Mode Select** to display the select mode panel.

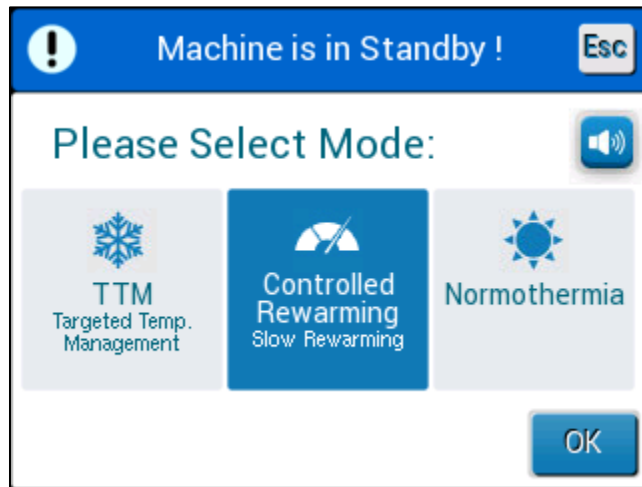

Figure 18: Select Mode Panel

3. Touch the required mode icon. The selected mode will be highlighted in blue.
4. Touch **OK** to activate the mode.

NOTE: *The selected mode is shown at the top of the control panel (see [The Control Panel](#)).*

The modes of operation include the following:

- TTM (Targeted Temperature Management)
- Controlled Rewarming
- Normothermia

TTM (Targeted Temperature Management)

Use TTM mode for targeted temperature management.

This mode is also useful for any procedure where thermoregulation is required to bring the patient's temperature to a stable set point temperature as quickly as possible. It may also be used when manually rewarming.

Adult/Neonatal setting impacts operation in TTM Mode, including default set points. See page [49](#) for additional information.

TTM Mode is described in further detail on page [63](#).

CONTROLLED REWARMING

This mode provides controlled gradual rewarming. The set point temperature is increased by a fixed, small step until the desired end normothermic temperature is reached.

The step is always related to the core temperature reached at the end of the previous stage. The rewarming rate per hour is selected in the Settings menu.

Adult/Neonatal setting does not impact operation in Controlled Rewarming Mode.

NOTE: *Controlled Rewarming Mode has a default Target Temperature of 36.5°C. Controlled Rewarming Mode is described in further detail on page [65](#).*

NORMOTHERMIA

Normothermia mode is for quickly reaching a normal body temperature.

Adult/Neonatal setting does not impact operation in Normothermia Mode.

NOTE: *Normothermia Mode has a default set point of 37.0°C.*

Normothermia Mode is described in further detail on page [74](#).



Temperature Graph

The temperature graph may be shown through the main menu or via the Temperature Graph Icon. 

CritiCool® displays either the current case parameters or the last session.

If the wrap or temperature probes are not connected, the last case is displayed.

To select Temp Graph:

1. Touch the MENU icon. 
2. Touch the Temperature Graph icon. 
3. Once entering the temperature graph, the following is shown:

NOTE: *The Surface (Surf) and Water Out (WOut) Temperature Graphs can be displayed or hidden.*

NOTE: *Water Out (WOut) is only displayed in Software Version 6.4.*

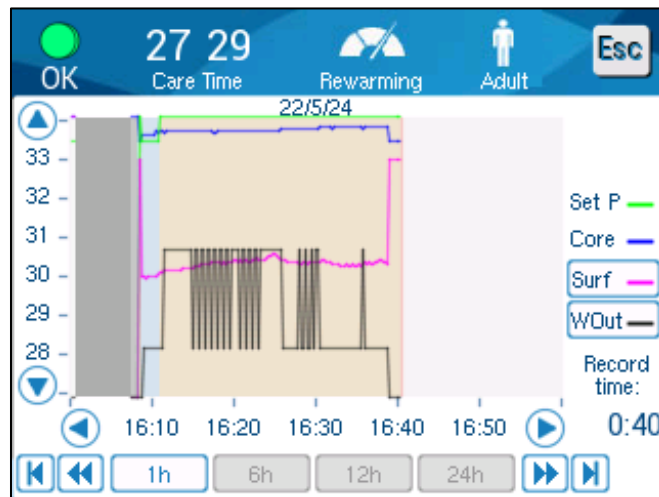
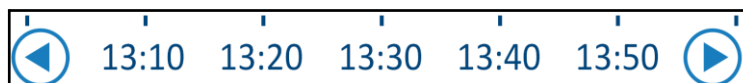

Figure 19: Temperature Graph

The date is displayed at the top of the graph.

The time from the beginning of the procedure is displayed on the X axis. The temperature is shown on the Y axis.

Move forward or backward the time of the graph displayed by using the arrow keys.



The screen can show 1 hour, 6 hours, 12 hours or 24 hours.
Use the double arrows to select the time range.



Settings

The settings panels consist of four pages of default settings for the system.

NOTE: *The settings menu is password protected. Only authorized personnel may change the settings.*

The passcode for the Settings screen is 6873.

To pre-configure the settings:

1. From the Menu panel, choose Settings.
2. Enter the password. The Settings window appears.
3. Touch the page numbers to move between the pages.

Settings Screen 1

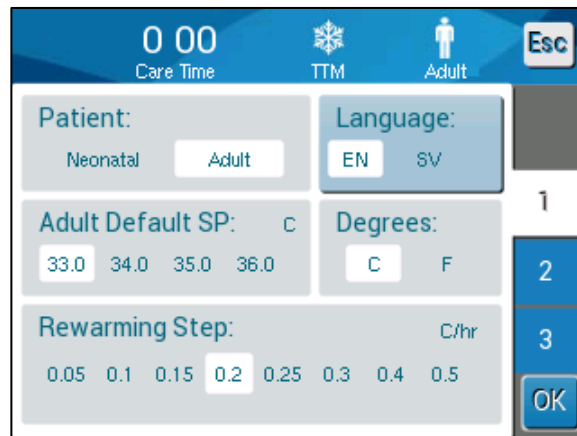

Figure 20: Settings Screen 1

Settings Screen 1 includes:

- Patient Mode: Adult or Neonatal
- Language
- Default Set Point Temperature for Adult TTM Mode
- Temperature Scales (Celsius/ Fahrenheit)
- Rewarming Rate Per Hour for Controlled Rewarming Mode

Settings Screen 2



Figure 21: Settings Screen 2

Settings Screen 2 includes adjustable alarm limits for:

- High Patient Temperature
- Low Patient Temperature
- High Water Temperature

Settings Screen 3

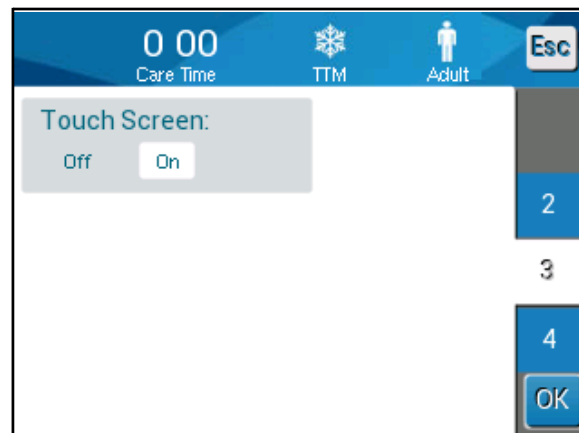

Figure 22: Settings Screen 3

Setting Screen 3 offers the ability to turn off the touch screen.

Settings Screen 4

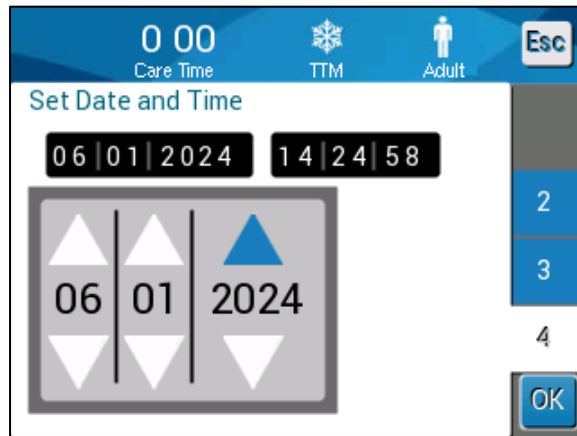

Figure 23: Settings Screen 4

Setting Screen 4 includes the Time and Date settings. To adjust, touch the digit being changed, and then adjust using the up and down arrows.

1. Touch **OK** to confirm settings changes and to return to the control panel.

NOTE: *Touching the ESC soft key returns to the main screen without saving any changes.*

Services

The Services option is in the Menu panel.

Services include the following:

- Empty
- System Check
- Technician
- Thermal Disinfection

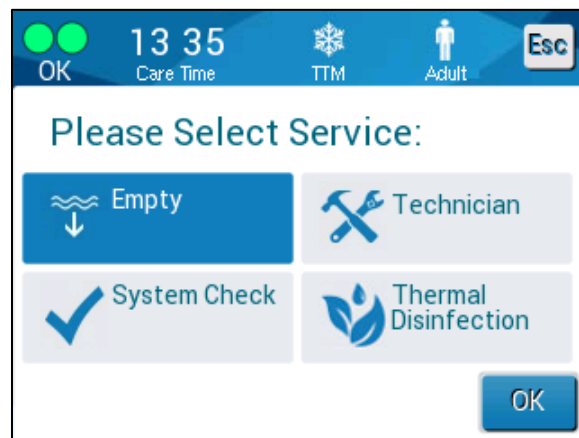



Figure 24: Service Menu

The System Check, Technician and Thermal Disinfections services are discussed in [Chapter 6: Maintenance](#).

Empty

This service allows emptying the system of the remaining water, prior to storing CritiCool®. Before storing CritiCool, NaDCC should be circulated. See Chapter 6: Maintenance.

To empty the water tank:

1. In an area away from patient care, with the system powered off, tightly clamp and then disconnect the wrap from the connecting water tubes. Dispose of the wrap.
2. Connect a male draining connector to the "water out" of the connecting water tubes and direct the tube to a bucket or sink for water collection.
3. Power on the system.
4. Choose **Empty** on the main screen or navigate to **Empty** by touching the **Menu**  icon, then selecting **Services**, then **Empty**.
5. Press **OK**. The following screen appears.

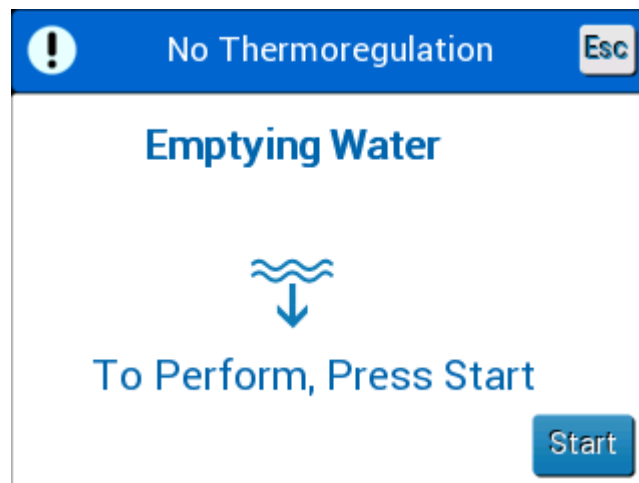

Figure 25: Start Emptying Panel

6. When you are ready for the process to begin, touch **Start**. The following screen appears.

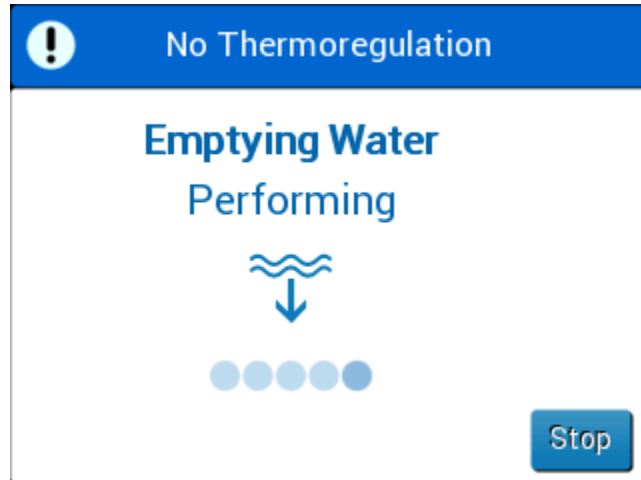

Figure 26: Emptying Water - Performing Panel

If the “Check Water Tubes” error message appears, it indicates that the male draining connector is connected to Water In, not Water Out. See below.

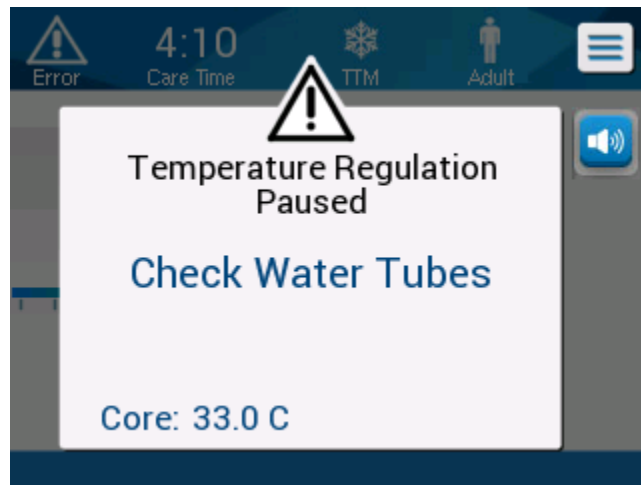

Figure 27: Check Water Tubes

The Water Out socket is indicated by the gray indicator with an arrow pointed down.



To resolve, press “Esc” on the screen. Keeping track of which tube was where, disconnect each connecting water tube at the machine end, then reconnect in the reverse way. Now the male draining connector should be connected to the tube inserted into Water Out. When done, follow the prior steps once more to continue emptying.

When the water has been emptied completely, a message appears stating that CritiCool® is now empty.

Shut down the system by turning the main power switch downwards to the OFF position. The main power switch is found on the rear of the device.

CritiCool® is now ready for storage until the next procedure.

For further instruction on after use care, consult “Before Storage” on page 90.

Modes of Operation

Targeted Temperature Management (TTM) Mode

Upon startup, the CritiCool® system prompts the user to confirm the mode, and an audio alarm sounds. TTM is highlighted by default.

When a mode is selected, a default Set Point (SP) temperature appears on the Main Screen.

The Set Point is the target temperature to which the thermoregulation system cools or warms the patient's body.

For Neonatal Mode, the set point default for TTM is 33.5°C (92.3°F).

For Adult Mode, the set point default for TTM is 33.0°C (91.4°F).

WARNING! *The default setting is intended to maintain TTM.*

In the Adult Mode, there is an option to configure the default set point temperature in the Settings screen (range is between 33°C to 36°C in steps of 1°C). The default Set Point temperature that is configured will be the Set Point temperature for the machine upon start up.

After start up, it is possible to change the TTM Set Point temperature in either patient mode for the current patient using the Set Point icon.

The system provides the physician with the option of selecting a body temperature in the range of 30°C-40°C (86°F-104°F).

WARNING! *The desired set point temperature should only be set by the physician or under the order of a physician.*

To change the set point temperature

1. Touch the Set Point icon  to display the Set Point Setting screen.
2. Press the temperature scales or use  and  to select the Set Point Temperature.

NOTE: The  and  icons change the temperature in 0.1°C increments. Pressing the temperature scales changes the temperature in 1°C increments.

3. When finished, touch **OK**.

After adjusting the set point, the CritiCool® system automatically operates at the optimal level to obtain the desired set point temperature. The set point should therefore be set upon mode selection and not changed until the patient needs to be rewarmed or there is another need to change the desired patient temperature.

NOTE: The rate of temperature changes depends on the size and weight of the patient.

Short transient changes in core temperature do not affect thermoregulation and are compensated by the system.

Controlled Rewarming Mode

This mode is used for slow, gradual rewarming following TTM.

In Controlled Rewarming Mode, CritiCool increases the set point automatically in small steps until it reaches a normothermic target temperature.

In this mode, the normothermic goal temperature is displayed as **Target Temperature**. The next rewarming step, or Rewarming Virtual Set Point (RSVP), displays as **Next Step**.

NOTE: *All thermoregulated patients should be closely monitored. Adjustments may still be required in Controlled Rewarming Mode.*

NOTE: *If unexpected temperature fluctuations are noted when maintaining patient temperature, either 1) closer monitoring, 2) a slower rewarming rate, 3) and/or manual rewarming is recommended.*

To set the hourly rewarming rate:

1. Touch the MENU icon .
2. Touch **Settings** in the Menu.
3. Insert password and press the **OK** button.

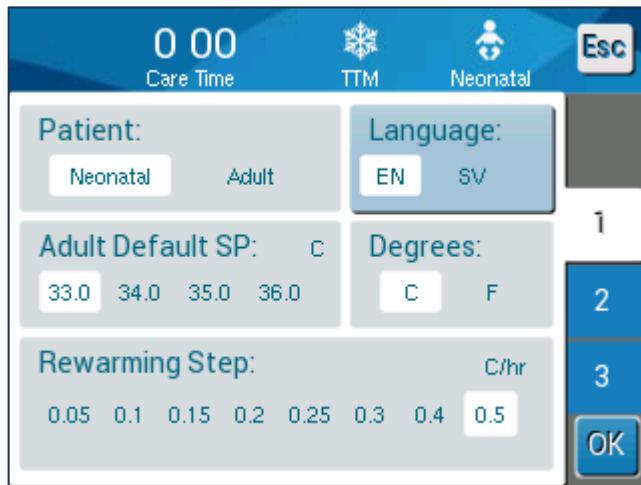

4. Choose the desired rewarming rate per hour (“Rewarming Step”).

The duration of the rewarming step depends on the rewarming step chosen:

- 30 minutes: rewarming rates of 0.15°C/hour or faster
- 1 hour: 0.10°C/hour rewarming rate
- 2 hours: 0.05°C/hour rewarming rate

NOTE: *Slower rewarming rates are recommended.*

5. Touch **OK** to return to the Main Screen.

NOTE: *If the rewarming rate is changed during rewarming, the user should reinitiate Controlled Rewarming Mode to immediately implement the new rewarming rate by selecting Menu, Mode Select, Controlled Rewarming. In version 6.4, this will result in maintaining core temperature for one rewarming step.*

Controlled Rewarming Process

The Controlled Rewarming process starts with the patient at a mild hypothermia temperature.

According to the pre-determined steps of rewarming, the system elevates the patient's temperature, each rewarming step, to a **Rewarming Virtual Set Point (RVSP)**. The RVSP is displayed on the screen in Controlled Rewarming Mode as the **"Next Step."**

For example:

The patient core temperature is 33.5°C and the selected step temperature elevation is 0.4°C/hour.

The Rewarming Virtual Set Point will be increased by 0.2°C every half hour. $33.5 + 0.2 = 33.7^\circ\text{C}$, therefore the goal over a period of 30 minutes would be 33.7°C.

Assuming that at the end of the 30 minutes period, the core temperature has reached 33.7°C, the Controlled Rewarming algorithm adds 0.2°C to the last virtual set point and the new virtual set point is now $33.7 + 0.2 = 33.9^\circ\text{C}$ for an additional 30 minutes, and so on, until the core temperature reaches the target temperature.

NOTE: *The rewarming rate chosen in Settings is the desired average rewarming rate over the course of the rewarming period. It would not be unusual if a patient warmed more in one period and less in another, as the algorithm compensates based on actual patient temperature, adjusting for multiple factors.*

To Start Controlled Rewarming (or Re-Initiate Controlled Rewarming):

1. Touch **MENU** icon .
2. Touch Mode Select to open the **MODE SELECT** panel.
3. Touch Controlled Rewarming.

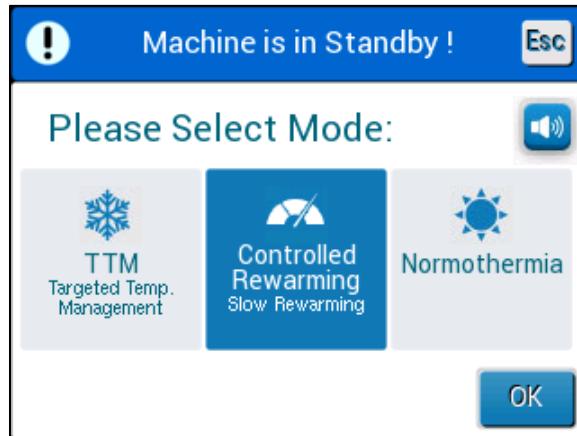

Figure 28: Select Mode Controlled Rewarming

4. Touch **OK**.

A message appears: “Switching to AutoRewarm Mode. Confirm Core in Place and Press OK.”

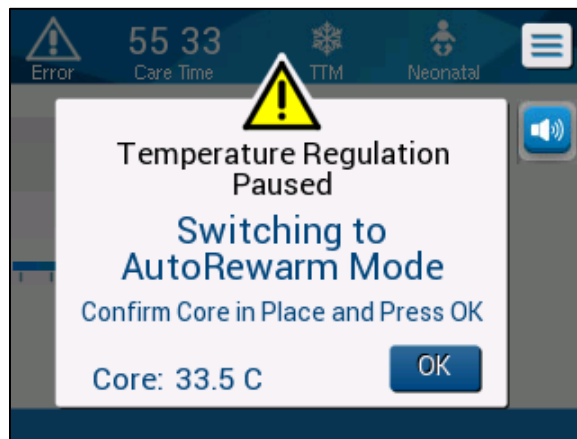

Figure 29: Switching to Rewarming Message

5. Confirm that the core temperature appears correct by checking the value on the screen, then that the probe is properly positioned, then again check the on-screen value. It may take up to two minutes for the values to stop fluctuating.

Once the core temperature appears stable, touch OK to start the rewarming process.

NOTE: *If "OK" is pressed before repositioning the probe or before values stabilize, an inaccurate core temperature may be used to calculate the Rewarming Virtual Set Point (RVSP).*

Controlled Rewarming Mode has now begun. CritiCool® continues circulation.

6. Confirm the patient core and skin temperatures shown on the screen appear accurate.
7. Follow the instructions below to change **Target Temperature**.

Target Temperature Setting



In the "Controlled Rewarming" mode, the Set Point display changes to "Target Temp". The target temperature is the temperature at which the controlled rewarming process ends.



The Target Temperature can be set between 32.0°C (86.0°F) to 38.0°C (104.0°F) with a default of 36.5°C (97.7°F).

NOTE: *This panel is accessible only in the Controlled Rewarming Mode.*

To change the Target Temperature:

1. Touch the Set Point/Target Temp icon .
2. Use  and  to modify the target temperature.



NOTE: The  and  icons provide a change of 0.1°C. Each scale mark in the toolbar provides a change of 1°C.



Figure 30: Target Temperature Setting Panel

Touch **OK** to confirm.

Target Temperature should now be displayed correctly.

The First Step of Controlled Rewarming (Software Version 6.4 only)

The flow icon starts to move, and a message appears “Holding Core Temp for First Step of Rewarming.”



Figure 31: Holding Core Temp for First Step of Rewarming

The message on the screen and core temperature will be maintained for the entirety of the first rewarming step. During this time, the Rewarming Virtual Set Point (RSVP) will be set to the current core temperature.

The duration of the temperature hold depends on the Rewarming Step selection in Settings (See page 65).

After the First Step of Controlled Rewarming (All Versions):

Upon completion of the first rewarming step, the system will reset the RSVP based on current core temperature and then proceed to increase the RSVP until the target temperature is reached. An accurate core temperature reading is vital for proper thermoregulation. Close monitoring is also necessary during thermoregulation, especially when rewarming.

NOTE: *If a power outage occurs when using Controlled Rewarming Mode, the user should reinitiate Controlled Rewarming Mode, then check that the parameters are correct. If incorrect, adjust parameters and then reinitiate Controlled Rewarming Mode. See page 72 for instructions.*

Completing Controlled Rewarming:

When core temperature reaches the target temperature, a message will appear “Target Temperature Has Been Reached.” (Software Version 6.4 only.) The message will remain for 60 minutes. See image below.



Figure 32: Target Temperature Has Been Reached

No message appears for software versions 6.3 and earlier.

CritiCool® continues to maintain the body temperature according to the target temperature.

- If done thermoregulating with CritiCool, refer to page 90 for instructions on preparing CritiCool for storage.
- If continued thermoregulation is desired, Normothermia Mode should be used. See page 74 for more information.

1. Choose Menu, Mode Select, then Normothermia Mode.

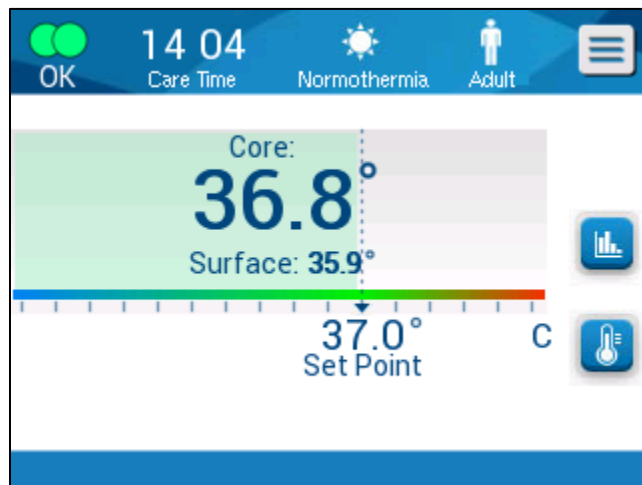

2. Adjust the Set Point temperature as needed.

Troubleshooting in Controlled Rewarming Mode:

Repositioning/Confirming Positioning of Core Probe

If rewarming seems unusual, first confirm that the core temperature probe is properly inserted and secure and that the reading is accurate and stable. It may take up to two minutes for the reading to stabilize.

When monitoring the patient or anytime the core probe dislodges from the patient, check the core probe, then consult the CritiCool screen and compare **Core** temperature against **Next Step**.

NOTE: *In the main screen, the "Next Step" (Rewarming Virtual Set Point) indicates the direction of core temperature in the immediate future. For most rewarming rates, it represents the goal core temperature for the next 30 minutes.*

Initiating/Reinitiating Controlled Rewarming Mode

If Next Step does not look correct, reinitiate Controlled Rewarming Mode by selecting Menu, Mode Select, Controlled Rewarming and reconfirming core temperature when the "Switching to Rewarming" message appears. This will recalculate the RSVP. In version 6.4, it will also result in holding the core temperature for the next step of rewarming.

"Core Readout Too Low" in Controlled Rewarming Mode

If, during the Controlled Rewarming phase, the core temperature becomes more than 2 degrees below the target temperature, or if rewarming is going significantly more slowly than expected, the following message appears:



Figure 33: Temperature Regulation Paused Message

NOTE: *While this screen is displayed, the machine is not thermoregulating the patient. Alarms should be promptly addressed.*

NOTE: *If this message flashes repeatedly, reinitiate Controlled Rewarming Mode.*

Check that the core probe is inserted correctly in the patient and then wait for the Core temperature reading on the screen to stabilize. This may take up to two minutes. Touch **OK** to continue rewarming.

More detailed information about “Core Readout Too Low” can be found on page [107](#).

Rewarming at an Unexpected Rate

To troubleshoot for rewarming faster or slower than desired, first:

1. Follow the guidance on page (See page [65](#)).
2. Confirm the core probe reading on the screen seems accurate by comparing the core and surface values.
3. Confirm that the hourly rewarming rate selected in Settings is appropriate (See page [65](#)).
4. Confirm that no environmental factors are contributing (overhead heating, room temperature, etc.)
5. Confirm that the wrap is properly positioned around the patient.

Then, after verifying the above, consider the following options:

Remaining in Controlled Rewarming Mode, maintain current core temperature for a time by changing the Target Temperature to match it (See Target Temperature Setting).

Reinitiate Controlled Rewarming Mode by selecting Menu, Mode Select, Controlled Rewarming and reconfirming core temperature when the “Switching to Rewarming” message appears. This will recalculate the RSVP. In version 6.4, it will also result in holding the core temperature for the next step of rewarming.

Rewarm the patient manually by using TTM Mode.
(See Manual Rewarming on page [74](#)).

Manual Rewarming

Manual rewarming provides the user with the most control over rewarming, as the user determines every step of the rewarming process. Manual rewarming may be more appropriate for higher risk patients or any patients with atypical temperatures or temperature fluctuations during the maintenance period.

To manually rewarm the patient, remain in TTM Mode once the maintenance phase has been completed. Select a set point that is slightly above the core temperature and wait until core temperature reaches the new set point. Then, increase the set point another step and wait for the core temperature to reach the next step.

Repeat the procedure until the patient reaches target temperature.

The set point step and the duration of each step depend on hospital protocol.

When choosing small steps, CritiCool® will keep water temperature close to body temperature. It is recommended to choose steps of 0.1°C – 0.25°C per 30 minutes during the rewarming phase.

For fast warming, choose Normothermia mode.

NOTE: *The desired set point temperature should only be set by the clinician.*

Normothermia Management

Use the Normothermia Mode for warming or cooling a patient to achieve or maintain normothermia.

NOTE: *This mode is used for quickly reaching a normothermic temperature. It does not allow for gradual controlled rewarming. It has no rewarming steps.*

Normothermia Mode

To initiate Normothermia Mode:

1. Go to the **Menu** icon .
2. Choose Select Mode.
3. Choose Normothermia.
4. Confirm by touching **OK**.

The Main Screen shows Normothermia Mode.

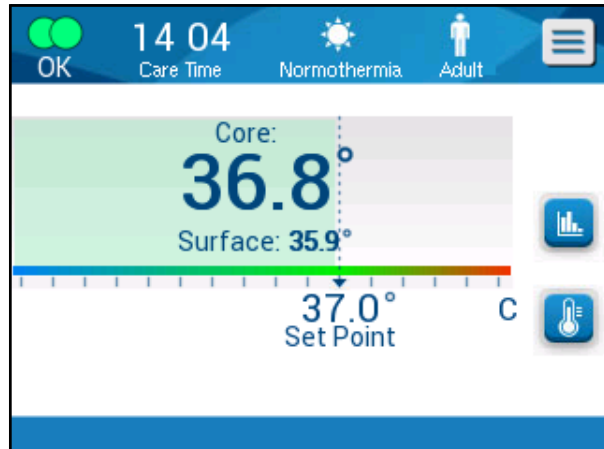





Figure 34: Normothermia Mode

NOTE: Adjust the desired set point temperature as needed.

To change the Set Point Temperature:

1. Touch the Set Point/Target Temp icon .
2. Use  and  to modify the Set Point Temperature.
3. Touch **OK** to confirm.

NOTE: The icons provide a change of 0.1°C. Each scale mark in the toolbar provides a change of 1°C.

Exceeding the Normothermia Range

If the desired set point temperature is set outside of the normothermia range, the message **OUT OF NORMOTHERMIA** appears.

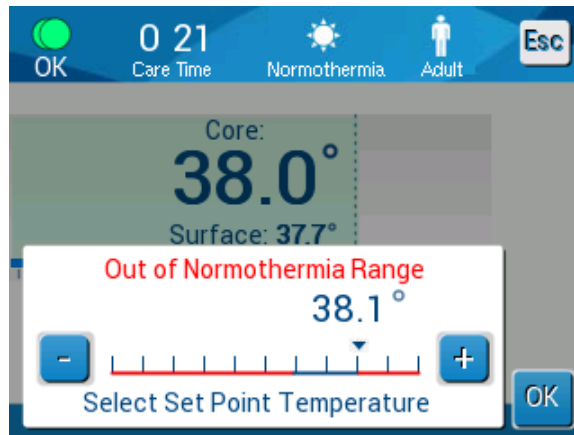

Figure 35: Out of Normothermia Range

Replacing the Wrap

To replace the wrap:

1. Switch to **STANDBY** and wait for the water return (by gravitation) to the system.
 2. After waiting a few seconds, push the wrap clamps to the very end (hose connection end) and clamp fully to avoid water leakage.
 3. Disconnect the connecting tubes from Wrap.
- WARNING!** *Avoid disconnecting tubes above electrical equipment as mild dripping may occur during disconnection.*
4. Remove the used wrap and dispose of according to hospital regulations.
 5. Position the new wrap underneath the patient (follow the Instructions for Use leaflet supplied with each wrap).
 6. Reconnect the connecting tubes to the new wrap.
 7. Confirm that the clamps on the new wrap are open.
 8. Add water to the water tank, as needed, up to the 6-liter line.
 9. Switch back to **OPERATE** mode (press **ESC/Menu** to access).
 10. Wait for the new wrap to fill up with water, then secure it to the patient with the Velcro strips (follow the Instructions for Use leaflet supplied with each wrap).
 11. The system is ready.

NOTE: *If there is not enough water in the tank after filling the wrap, the system alert message **ADD WATER** appears.*

Operation Panel Messages and Alerts

More minor messages appear at the bottom of the screen as notes. Figure 37 provides an example.

The following messages appear as notes:

- Low Core Temperature. Thermoregulation is Continuing...
- Out of Normothermia Range
- Patient Mode Changed. Check Set Point.
- Holding Core Temperature for First Step of Rewarming.
- Target Temperature Has Been Reached
- Patient Temperature Above XX.X°C (*)
- Patient Temperature Below YY.Y °C (*)
- Water Temperature Too High (*)

NOTE: *Only authorized users can change the range of the alarms marked by (*) in the Settings screen. The user needs to insert a password to enter the Settings panel and change the alarm limit.*

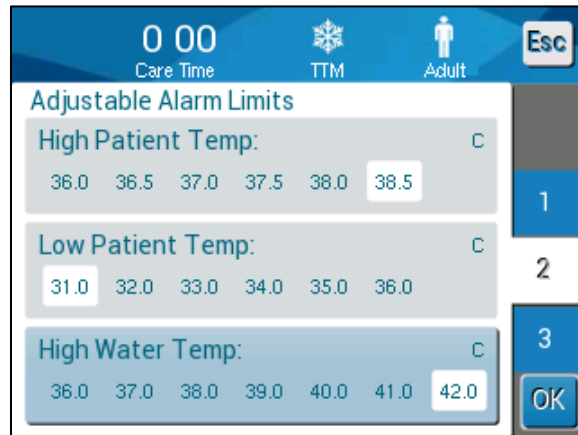



Figure 36: Adjustable Alarm Limits

More severe messages cover most of the screen and feature a triangular sign . Figure 38 on page 79 provides an example.

If the wrap's tubes are connected, temperature probes are connected correctly, core temperature is measured, and an active mode has been selected, water circulation will start without additional user action. If any of the above conditions is not fulfilled, the operation panel message area displays technical and/or clinical alarm messages with a triangular sign .

NOTE: During safety messages, thermoregulation stops.

NOTE: Clinical alarms represent medium priority alarms while technical messages represent lower priority alarms.

NOTE: Sound Pressure of the Alarms is 67.5 dBA at a distance of 10 centimeters.

Constant alarms occur in the following states:

- Halt condition (see page 43).
- Select mode screen (see page 55).

More information on alarms and messages can be found in the Troubleshooting Guide beginning on page 98.

TTM Mode Messages

The thermoregulation system may have one of three conditions:

1. Core temperature above the Set Point [$T_c \geq (T_{sp} - 0.8^\circ\text{C})$]

In this condition, temperature control starts without any user action.

1.1. Core temperature is above 30.8°C but lower than the Set Point by 0.8°C

$$[30.8^\circ\text{C} < T_c < (T_{sp} - 0.8)]$$

In this condition, temperature control continues and warms the patient toward the set point.

An informative message appears and an audible alarm sounds. Pressing MUTE stops the alarm for 30 minutes. The written message on the screen is removed only when $\Delta \leq 0.6^\circ\text{C}$.

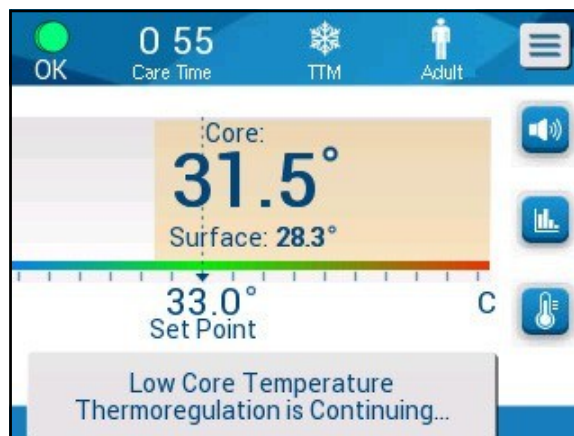

Figure 37: Low Core Temperature Message

1.2. Core temperature is lower than the Set Point by 2°C or more ($\Delta (T_{sp} - T_{core}) > 2^{\circ}\text{C}$) or if $T_c < 30.8^{\circ}\text{C}$

This message could indicate that the core temperature probe might be out of place.

The following message appears: “Temperature Regulation Paused. Core Readout Too Low. Confirm Sensor Position. Press OK to Continue.”

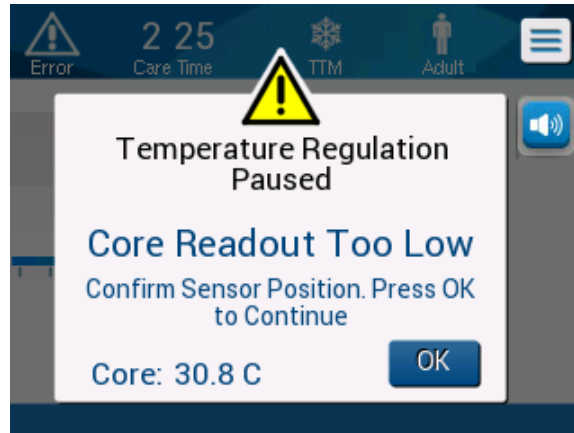

Figure 38: TTM Mode: Core Readout Too Low Message

An audible alarm sounds.

Touching the hard key next to the Alarm icon  will mute the alarm for **five** minutes but leave the message on the screen.

NOTE: *If the Core Temperature is below 30.5°C, the alarm cannot be silenced.*

NOTE: *If the user disregards the message and does not touch OK for over 30 minutes, the alarm cannot be silenced.*

While the message appears, thermoregulation is paused.

Check that the core temperature probe is in place and the low temperature represents the true patient status and then touch OK to re-activate temperature control.

If the user presses OK but does not resolve the issue, the alarm will sound again in 30 minutes. If the issue is resolved without user involvement, this alarm will resound when conditions are met, regardless of whether 30 minutes has passed.

While the message appears the system, status is:

1.3. In Adult Mode:

- **If Core > 30.8°C:** Thermoregulation is paused, but the machine continues to flow water to the wrap.
- **If Core < 30.8°C:** Thermoregulation is paused, and water stops flowing to the wrap.

1.4. In Neonatal Mode:

- Thermoregulation is paused, and water stops flowing to the wrap.

Check that the core sensor is in place and the low temperature represents the true patient status.

Then touch **OK** to re-activate temperature control.

NOTE: *If you disregard the message and do not touch OK for over 30 minutes, the alarm cannot be silenced.*

When **OK** is touched, the screen returns to the main screen, and the following message appears for 5 seconds.



Figure 39: Thermoregulation is Continuing Message

This message indicates that water is now flowing into the wrap and that thermoregulation is continuing.

Controlled Rewarming Mode Messages

During Controlled Rewarming, there may be two conditions:

1. **Virtual Set Point (VSP) Temperature - Patient Core Temp $>0.8^{\circ}\text{C}$ and $<2^{\circ}\text{C}$:**

In this case, a message appears with an alarm, but thermoregulation continues.

2. **Patient Core Temperature $<$ Target Temperature and (Δ Virtual SP-Core Temperature) $>2^{\circ}\text{C}$**

This means that the core temperature probe is probably out of the body.

An audible alarm sounds, and the following message appears:



Figure 40: Controlled Rewarming Mode: Core Readout Too Low Message

Pressing MUTE disables the audible tone. The alarm restarts after **5** minutes.

While the message “Core Readout Too Low” appears in Controlled Rewarming Mode, the machine is not regulating the patient’s temperature, and no water is flowing to the wrap.

Check that the core temperature probe is in place and the low temperature represents the true patient status, then touch **OK** to re-activate temperature control.

NOTE: *If the User disregards the message and does not touch **OK** for over 30 minutes, the alarm cannot be silenced.*

When **OK** is touched, the screen returns to the Main Screen, and the following message appears for 5 seconds.

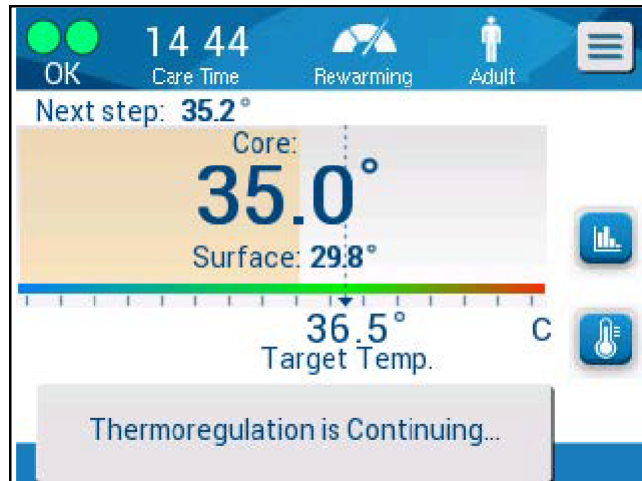

Figure 41: Thermoregulation is Continuing Message

Chapter 5: Ordering Information

Equipment and Accessories

All equipment and accessories may be ordered directly from your local Belmont Medical Technologies representative or your local authorized distributor. When ordering parts, specify the part number listed in this chapter as well as the serial number of your CritiCool® system.

Available Wraps

Models for various wraps are available. Refer to [Table 5](#).

Table 5: Wrap Information

CureWrap®	Type	Part Number /Box /Singles	Number of Wraps Per Box	Patient Size/ Weight	Wrap Height / Width (m)
CureWrap® Pediatric	Infant (Single Size)	508-03518	8/Box	2.5 – 4 Kg	0.659/0.448
		500-03518	8/Box		
	Small/Infant (Assorted)	508-03521	8/Box	4 – 7 Kg	0.698/0.602
		500-03521	8/Box		
	Medium (Assorted)	PED-SM008	8/Box	2.5 – 4 Kg	0.659/0.448
		500-03518	4/Box		
	Large (Assorted)	500-03521	4/Box	4 – 7 Kg	0.698/0.602
		PED-MD008	8/Box		
	X-Large (Assorted)	500-03525	4/Box	7 – 11 Kg	0.981/0.628
		500-03531	4/Box		
Adult (Single Size)	PED-LA008	8/Box	91 – 104 cm	1.225/0.841	
	500-03536	4/Box			
Adult (Single Size)	500-03541	4/Box	104 – 122 cm	1.390/1.054	
	PED-XL008	8/Box			
Adult (Single Size)	500-03548	4/Box	122 – 135 cm	1.582/1.1193	
	500-03500	4/Box			
CureWrap® Adult	Adult (Single Size)	508-03500	8/Box	Over 135 cm	2.030/1.354
		500-03500	8/Box	Over 135 cm	2.030/1.354

Available Accessories

One accessory kit is provided with each system. The CritiCool Accessory Kit is available in four configurations: two with reusable temperature probes (PN# 200-00300 and PN# 200-00320) as shown in [Table 6](#) and [Table 7](#) and two with adapter cables for use with disposable temperature probes (PN# 200-00310 and PN# 200-00330) as shown in [Table 8](#) and [Table 9](#).

Disposable temperature probes need to be ordered separately. [Table 10](#) lists common accessories that can be ordered individually.

Table 6: CritiCool Infant Reusable Accessory Kit (PN# 200-00320)

Sub Part No.	Description	Number Supplied
014-00005	Reusable Infant Core Temperature Probe, Gray (10FR)	1
014-00021	Reusable Surface Temperature Probe, Green	1
200-00109	Connecting Water Tubes 2 by 2 Way	1
200-R0130	Filter unit (internal)	1
DDT136009	CritiCool® Infant Step by Step Guide	1
405-00015	CritiCool Disinfection Kit	1

Table 7: CritiCool Adult Reusable Accessory Kit (PN# 200-00300)

Sub Part No.	Description	Number Supplied
014-00020	Reusable Adult Core Temperature Probe, Gray (12FR)	1
014-00021	Reusable Surface Temperature Probe, Green	1
200-00147	Connecting Water Tubes 2 by 3 Way	1
200-00109	Connecting Water Tubes 2 by 2 Way	1
200-R0130	Filter unit (internal)	1
DDT136011	CritiCool® Adult Step by Step Guide	1
405-00015	CritiCool Disinfection Kit	1

Table 8: CritiCool Infant Disposable Accessory Kit (PN# 200-00330)

Sub Part No.	Description	Number Supplied
014-00028	Adapter Cable for Disposable Core Temperature Probe, Gray	1
014-00324	Adapter Cable for Disposable Surface Temperature Probe 3.5 mm (1/8") Mono Jack, Green	1
200-00109	Connecting Water Tubes 2 by 2 Way	1
200-R0130	Filter unit (internal)	1
DDT136009	CritiCool® Infant Step by Step Guide	1
405-00015	CritiCool Disinfection Kit	1

Table 9: CritiCool Adult Disposable Accessory Kit (PN# 200-00310)

Sub Part No.	Description	Number Supplied
014-00028	Adapter Cable for Disposable Core Temperature Probe, Gray	1
014-00324	Adapter Cable for Disposable Surface Temperature Probe 3.5 mm (1/8") Mono Jack, Green	1
200-00147	Connecting Water Tubes 2 by 3 Way	1
200-00109	Connecting Water Tubes 2 by 2 Way	1
200-R0130	Filter unit (internal)	1
DDT136011	CritiCool® Adult Step by Step Guide	1
405-00015	CritiCool Disinfection Kit	1

Table 10: Accessories

Part Number	Description
014-00035	Disposable Core Temperature Probe, 9 Fr, Smiths Medical ER400-9 (20/pack)
014-00036	Disposable Core Temperature Probe, 7 Fr, Metko FMT400/AOR-D2 (40/pack)
014-00220	Disposable Core Temperature Probe, 9 Fr, DeRoyal 81-020409 (50/pack), USA ONLY
014-00038	Disposable Core Temperature Probe, 9 Fr, TE Measurement Specialties 4491 (20/pack), USA ONLY
014-00221	Disposable Surface Temperature Probe YSI 400, DeRoyal 50/pack, USA ONLY
014-00323	Disposable Surface Temperature Probe, 3.5 mm (1/8") Mono Jack, Metko 50/pack
002-00069	Male Connector for Draining Water Tank
200-R0130	Filter Unit (internal)
017-00250	CliniLogger™
200-00109	Connecting Water Tubes 2 by 2 Way
200-00147	Connecting Water Tubes 2 by 3 Way
014-00005	Reusable Core Temperature Probe Infant, Gray (10FR)
014-00020	Reusable Core Temperature Probe Adult, Gray (12FR)
014-00021	Reusable Surface Temperature Probe, Green
014-00028	Adapter Cable for Disposable Core Temperature Probe YSI 400, Gray
014-00324	Adapter Cable for Disposable Surface Temperature Probe, 3.5 mm (1/8") Mono Jack, Green
405-00015	CritiCool Disinfection Kit

Chapter 6: Maintenance

Introduction

This chapter outlines the maintenance instructions for the CritiCool® system. Trained hospital staff may perform routine maintenance unless otherwise specified.

WARNING! *The repair and servicing of the CritiCool® system should be performed only by Belmont Medical Technologies or authorized agents of Belmont Medical Technologies.*

Service Information

When communicating with authorized Belmont Medical Technologies representatives regarding the CritiCool® system, please provide the software version and serial numbers on the identification label located on the rear panel of the CritiCool® device (see [Figure 4](#)).

When communicating regarding wraps, refer to the label on the wrap package for lot number details.

Routine & Preventive Maintenance

The CritiCool® system should be inspected and maintained as noted in [Table 11](#) to make sure that it remains in optimum condition.

Table 11: Inspection and Maintenance Schedule Overview

Frequency	Inspection/Service	Performed By
Before each use	<ul style="list-style-type: none"> • Clean connecting tubes and Quick Coupling Connector with a wet cloth. • Perform a visual inspection for any mechanical failure in probes, connecting tubes, and power cable. • Perform a visual inspection of the exterior of the CritiCool® System. 	Clinician or Hospital Staff
As required by hospital/clinic protocol	<ul style="list-style-type: none"> • Routine external cleaning and disinfecting. • Replace Connecting Water Hoses (PN #200-00109 and 200-00147) periodically. 	Clinician or Hospital Staff
Per instruction found in "2. DISINFECTION FREQUENCY"	<ul style="list-style-type: none"> • Disinfect water circuit. 	Clinician or Hospital Staff
Annually	<ul style="list-style-type: none"> • Periodic Maintenance • Replace filter * • Thermal Disinfection application (optional) 	Belmont Medical Technologies authorized technician

* Filter replacement could be performed if needed more frequently than once a year (according to water quality) if needed.

Routine Maintenance Overview

Cleaning and disinfection of the external surface should be done before each use of the system. The system components may be contaminated during use and storage of the system from numerous factors.

CAUTION!

- Do not use any kind of brush on the machine touch screen or its accessories.
- Do not submerge the machine in liquid.
- Do not wash the electrical power socket.
- Do not use any saline or irrigated fluids.
- Do not use any ester solvents.
- Always check reusable temperature probes and cables for scratches and tears before and after cleaning. If the probe is damaged, do NOT use it.

For reusable temperature probes, follow the manufacturer's recommendations and always check the temperature probes for scratches and tears before and after cleaning. If the probe is damaged, do NOT use it.

NOTE: *Follow your hospital protocols for disinfecting the product.*

Cleaning & Disinfecting External Surfaces

Required Tools for Cleaning of External Surfaces

- PPE (Personal Protective Equipment) according to the disinfectant manufacturer's instructions.
- Clean cloths (lint-free recommended)

Recommended Disinfectants for External Surfaces

- Chlorinated bleach solution (5.25% sodium hypochlorite concentration)
- Quaternary ammonium compounds (ammonium chloride as active ingredient)
- Germicidal Disposable Wipes (Sani-Cloth® or equivalent)

Before Each Use

CAUTION! *Apply finger pressure only. External instruments exert excessive pressure on the screen and should not be used.*

1. Use PPE as recommended by the disinfectant's manufacturer.
2. Make sure that the system is turned off and unplugged from power.

3. Using a clean cloth with sterile water, clean the exterior of the machine and the LCD screen from any soiling.
4. Prepare the disinfectant solution as described by the manufacturer and follow the manufacturer's directions for time duration and concentration.
5. Using a clean cloth with the disinfectant, disinfect the exterior of the machine, the LCD screen, and the hoses.
6. For residue removal, use a new clean cloth moistened with sterile water. Use the cloth on the exterior of the system, the screen, and the hoses.

After Each Use



1. Use PPE as recommended by the disinfectant's manufacturer.
2. With the system in Standby Mode, disconnect the temperature probes from the patient.
3. Dispose of disposable temperature probes in accordance with hospital procedures for medical waste. Disinfect reusable temperature probes or adapter cables as required by the manufacturer's directions.
4. Close the clamps on the wrap.
5. Remove the wrap from the patient; disconnect it from the hoses and dispose of it.
6. Disconnect the hoses and adapter cables from the machine and then wipe with alcohol.
7. Turn off the machine. Unplug the power cord.

Cleaning, Disinfecting and Sterilization of the Reusable Temperature Probes

The cleaning, disinfection and sterilization of the reusable temperature probes are according to the manufacturer's instruction.

Disposable probes are not to be reused. Improper use can lead to cross contamination and deterioration of safety.

Water Circuit Disinfection Instructions

1. REQUIRED TOOLS FOR WATER CIRCUIT DISINFECTION				
A.	Temperature Management Disinfection Kit (P/N 405-00015) includes:			
	2-Connector Bypass Tube	Quantity x 1	P/N 200-00181	
	3-Connector Bypass Tube	Quantity x 1	P/N 200-00098	
	Temperature Simulator	Quantity x 1	P/N 017-00245	
B.	PPE (Personal Protective Equipment) per the NaDCC tablet manufacturer's instructions.			
C.				Sodium Dichloroisocyanurate (NaDCC) tablets in the recommended concentration
D.	Hospital-grade disinfecting wipes			
E.	Sterile water / 0.22µm filtered water (approximately 12 Liters total) <i>NOTE: Do not use de-ionized water or water created through reverse osmosis as it may promote corrosion of the metal components of the system.</i>			

2. DISINFECTION FREQUENCY
Prior to First Use
At Least Once Every 3 Months
Before Long-Term Storage (>3 Months)
Before Use Following Long Term Storage of >3 Months

***NOTE:** Disinfection can be performed more frequently if the hospital protocol dictates.*





***NOTE:** If a patient, clinician, or biomatter comes in contact with the water circuit disinfect immediately after.*



NADCC CONCENTRATION RECOMMENDATIONS

Tablets needed to achieve at least a 5382 ppm concentration of NaDCC

PurTabs® (13.1g)	Klorsept® 87 (17.4g)	Aquatabs® (8.68g)
8 Tablets per 6 L of water	7 Tablets per 6 L of water	7 Tablets per 6 L of water







3. DEVICE PREPARATION AND DISINFECTION

A.		<p>Ensure the device is powered OFF. Check the water tank level. If the water level is below the lower red line, add room temperature sterile or 0.22µm filtered water until the water level is between the 2 red arrows to ensure the machine has 6 L.</p> <p>NOTE: Alternatively, you can prepare this disinfection solution in a separate container per the NaDCC tablet manufacturer's instructions.</p>	
B.	PPE Required	Use the appropriate PPE per the NaDCC tablet manufacturer's instructions for use.	
	Add NaDCC	<p>Remove the cap, chain, and anchor ring from the device's water tank.</p> <p>Procure the appropriate NaDCC tablets and add the correct number to the device's water tank (see above).</p> <p>NOTE: Do not disinfect water circuit near the area of care.</p>	
C.			<p>Allow the tablets to dissolve for 15 minutes.</p> <p>While tablets are dissolving, perform the remaining steps in Step C.</p> <p>NOTE: Do not leave the dissolved tablet solution stagnant in the device's water tank for more than 20 minutes.</p>
	2-Connector	3-Connector	<p>Wipe clean the cap, chain, and anchor ring with hospital-grade disinfecting wipes, then reattach the cap, chain, and anchor ring.</p> <p>Connect the blue hoses (P/N 200-00109) to the 2-connector bypass tube assembly (P/N 200-00181). Connect the other ends of the blue hoses to the device.</p> <p>NOTE: If you have blue hoses with 3 connectors on one end (P/N 200-00147), use the 3-connector bypass tube assembly (P/N 200-00098).</p>
	P/N 200-00181	P/N 200-00098	
			

D.	Plug in the device, power it ON , and allow the Self-Test to complete.	
E.		Select and operate the device in Normothermia mode. Set the patient setpoint to 37°C.
F.		Plug the temperature simulator (P/N 017-00245) into the core temperature socket on the front of the device and set it to 36.0°C ±0.3 by turning the dial and watching the display.
G.		Allow the solution to circulate for 5 minutes (minimum) to 6 minutes (maximum) to disinfect the device's water circuit . Place the device into Stand-by mode once completed.
H.	If you have a second set of blue hoses, disconnect the current set and attach the second set using the appropriate bypass tube assembly. Repeat Steps G – I.	
I.	Remove the bypass tube assembly from the connected blue hose set. Drain the solution from the device's water tank following the instructions found in Chapter 4 – "To empty the water tank:" Note: Dispose of the cleaning solution per hospital protocol.	
J.	Flush Cycle	Proceed to Section 4: FlushCycle to complete the disinfection and cleaning procedure.

4. FLUSH CYCLE

NOTE: Device **MUST** be flushed. If the device is not flushed, damage to the device's internal components may occur.

A.		<p>Refill the device with 6 L of sterile or 0.22µm filtered water (no NaDCC).</p>	
B.			<p>Reconnect the appropriate bypass tube assembly to the blue hoses still connected to the device.</p>
C.			<p>Place the device back into Normothermia mode with the temperature simulator still set to 36.0°C ±0.3. Allow the water to circulate for at least 5 minutes before placing the device in Stand-by mode.</p>
D.	<p>If you have a second set of blue hoses, disconnect the current set and attach the second set and appropriate bypass tube assembly. Repeat Step C.</p>		
E.	<p>Remove the bypass tube assembly from the connected blue hose set. Drain the solution from the device's water tank following the instructions per Chapter 4 – "To empty the water tank:"</p> <p>Refill the device with 6 L of room temperature sterile or 0.22µm filtered water if returning to use or leave tank empty if moving to storage.</p>		
F.	<p>Power OFF the device, unplug it and disconnect the blue hoses. Disconnect and store the temperature simulator (P/N 017-00245).</p>		
<p>DEVICE IS NOW READY FOR STORAGE OR NEXT PATIENT</p>			
		<p>Scan the QR code to watch the CitiCool® Water Circuit Disinfection Video</p>	

Thermal Disinfection (Self-Cleaning)

This feature performs a thermal disinfection of the water tank and internal tubing and is optional.

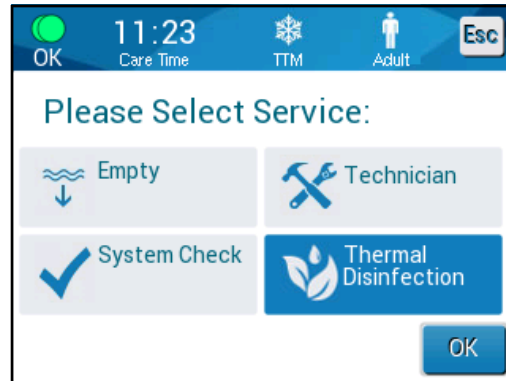

The thermal disinfection of CritiCool® is an integrated feature, which heats the circulating water of the system, thus allowing the heat to disinfect the internal water pathways of the system, including the water tank.

Thermal disinfection is performed at every periodic maintenance and can only be performed by a Belmont certified technician.

Thermal disinfection is performed once per year (optional).

Refer to the Service Manual for more information.

System Check Service

The System Check service is initiated from the Services menu.

The System Check service performs a complete check of the system by checking the functionality of the following components:

- Screen and buzzer
- Pump
- Wrap connection
- Pressure meter
- Heating and Cooling unit
- Temperature of water inflow and water outflow

Successful completion of the system check service indicates that the CritiCool® system is operational.

NOTE: *If the CritiCool® was out of use for a long time, a full System Check should be performed.*

To perform system check:

NOTE: Before performing System Check, verify that the water tank is full.

1. In the main menu, select **Services**. The following window appears:



Figure 42: Selecting System Check

2. In the **Services** screen, select **System Check** then click **OK** to confirm. A message appears requesting you to confirm start of System Check.

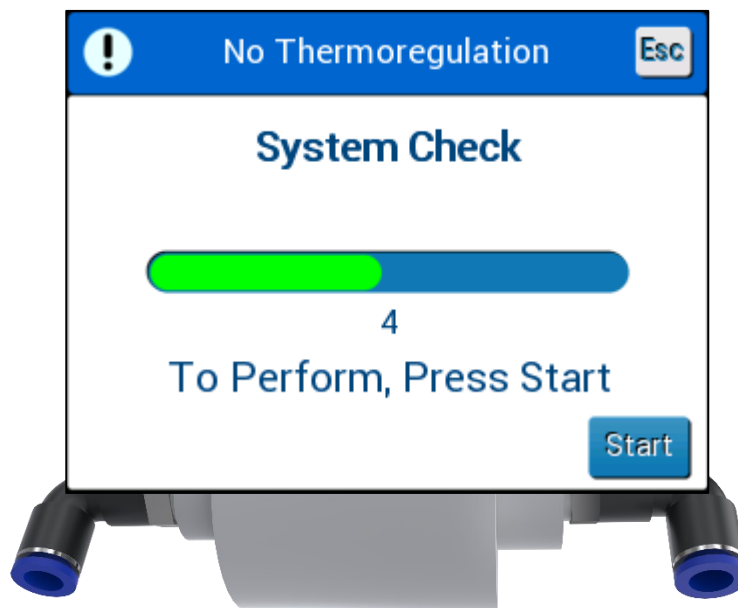

Figure 43: System Check in Progress

3. Touch **Start**.

System Check is initiated. The progress bar that appears on the screen indicates the progress.

System Check takes about 10 minutes.

When the process is completed, a message appears on the screen "SYSTEM CHECK COMPLETED".

4. Switch to the Operation screen.
5. Turn CritiCool® off.

Filter Replacement

The filter is for filtering hard soils or large particles. It is not intended for filtering the water from bacterial contamination.

The filter must be replaced every twelve months at a minimum.

NOTE: *The filter should be replaced only by Belmont Medical Technologies authorized personnel. See the Service Manual for replacement instructions.*

Chapter 7: Troubleshooting

General

The CritiCool® system is equipped with self-testing routines that continuously monitor system operation. If a system fault or malfunction is detected, a fault message appears. Should a malfunction occur, consult the Troubleshooting Guide.

Troubleshooting Guide

[Table 12](#) and [Table 13](#) list some possible scenarios that may indicate a malfunction, their cause, and recommended actions.

WARNING! *The repair and servicing of the CritiCool® system should be performed only by Belmont Medical Technologies or authorized agents of Belmont Medical Technologies.*

Table 12: CritiCool System Malfunction (no message) Troubleshooting Guide

Observation	Possible Problem	Action to be Taken
The power switch of the CritiCool® system is set to "ON" but it is not activated, and the control panel is blank.	CritiCool® system is unplugged.	Check the 100, 115/230 VAC power cable connections.
	No line voltage	Call Biomedical Department.
Wrap begins to leak.	The wrap was accidentally punctured during operation.	Turn off the CritiCool® system and allow the water to return to the reservoir. Replace the Wrap if possible.
Water leaks from the connector between Wrap and the connecting tube.	Connecting tubes are not sealed properly.	Close clamps on Wrap. Disconnect connecting tubes and re-connect connecting tubes until the click sound is heard.
	Damage to connecting tubes.	Replace connecting tubes.
	Damage to quick coupling connector.	Call Biomedical Department.
Water leaks between connecting tubes and the CritiCool® device.	Connecting tubes are not connected properly.	Disconnect connecting tubes from the machine and re-connect again until the click sound is heard.
	Damage to connecting tubes.	Replace connecting tubes.
	Damage to Quick coupling connector.	Call Biomedical Department.
The message "Core Readout Too Low" appears when the message should not have triggered (core temperature is as expected).	Both the core and surface sensors are unplugged.	Connect core and surface sensors, matching colors and ensuring the core probe is connected into the core socket. Wait for the core temperature reading to stabilize. Then press OK. Press Standby Mode. Power off or continue using device by initiating a mode in Mode Select.

Observation	Possible Problem	Action to be Taken
The "Thermoregulation is Continuing" message does not appear when expected.		The system is thermoregulating properly. No action needed.
The "Body Temperature in Accepted Range" message does not appear when expected.		The system is thermoregulating properly. No action needed.
In the Mode Select Screen, the selected mode is not highlighted.	In the Mode Select Screen, the selected mode becomes unhighlighted after 10 seconds.	Reselect the intended mode and press OK to initiate the mode or press ESC to return to the prior operating mode.

NOTE: A muted alarm is activated when a subsequent message appears

Table 13: CritiCool Controlled Rewarming Mode Troubleshooting Guide

Observation	Possible Problem	Action to be Taken
"Next Step" displayed on the screen does not seem correct when compared to Core and Target Temperature.	The rewarming rate was changed when using Controlled Rewarming Mode and calculated incorrectly.	Reinitiate Controlled Rewarming. Press Menu, Mode Select, Controlled Rewarming, OK. Check the core probe, reposition if necessary and wait for the core temperature reading to stabilize. Press OK. Verify all parameters are correct and adjust if needed. See page 72.
	When prompted to confirm core probe and press OK, when OK was pressed, the core probe was partially or fully dislodged , resulting in an incorrect core temperature reading at time of rewarming step calculation.	Check the core probe, reposition if necessary and wait for the core temperature reading to stabilize. Press OK. Reinitiate Controlled Rewarming. Press Menu, Mode Select, Controlled Rewarming, OK. Verify all parameters are correct and adjust if needed.

Observation	Possible Problem	Action to be Taken
		See page 72.
	When prompted to confirm core probe and press OK, OK was pressed when the core temperature values on the screen were fluctuating , resulting in an incorrect core temperature reading at time of rewarming step calculation.	Check the core probe, reposition if necessary and wait for the core temperature reading to stabilize. It may take up to two minutes for the reading to stabilize. Press OK. Reinitiate Controlled Rewarming. Press Menu, Mode Select, Controlled Rewarming, OK. Verify all parameters are correct and adjust if needed. See page 72.
Parameters are not maintained after a short power interruption of 10 minutes or less. “Next Step” displayed on the screen does not seem correct when compared to Core and Target Temperature.	A power outage lasting less than 10 minutes occurred when using Controlled Rewarming Mode.	Reinitiate Controlled Rewarming Mode (Press Menu, Mode Select, Controlled Rewarming, OK). Check the core probe, reposition if necessary and wait for the core temperature reading to stabilize. Press OK. Verify all parameters are correct and adjust if needed. See page 72.
A message on the screen appears “Holding Core Temp For First Step of Rewarming” when Controlled Rewarming Mode has not been initiated.	A power outage lasting less than 10 minutes occurs when using Controlled Rewarming Mode.	The device is rewarming appropriately. Press Menu, Standby, then Operate. The message will disappear.
The “Core Readout Too Low” message flashes repeatedly in Controlled Rewarming Mode.	The mode did not initiate properly.	Reinitiate Controlled Rewarming. Press Menu, Mode Select, Controlled Rewarming. Check the core probe, reposition if necessary and wait for the core temperature reading to stabilize. Press OK. Verify all parameters are correct and adjust if needed.

Observation	Possible Problem	Action to be Taken
		See page 72.
At the end of Controlled Rewarming, patient temperature differs from the target temperature by $\leq 0.3^{\circ}\text{C}$.	Once core is within $\leq 0.3^{\circ}\text{C}$ of target temperature, target temperature is considered to have been reached.	Switch to Normothermia Mode. Press Menu, Mode Select, Normothermia Mode, OK. Verify the set point temperature and adjust if needed.

Table 14: Draining CritiCool / Water Tank Overfilled



Observation	Chapter 7: Troubleshooting
Water tank overfilled.	<p>It is necessary to drain the water tank after each use:</p> <ol style="list-style-type: none"> 1 Connect one connecting tube to the right quick coupling connector. 2 Connect the special male connector to the water-out connecting tube (the gray end if using the 2x3 Way Connecting Water Hoses).  <ol style="list-style-type: none"> 3 Turn the CritiCool® device ON. 4 Select Empty mode in Services. 5 Prepare to allow the excess water to drain into a receptacle, pail or sink. 6 Water should begin once Start has been pressed. If it does not, exit from Empty mode, disconnect the special male connector from the current connecting tube, connect it to the other connecting tube instead, then begin. 7 A message will appear when the water tank is empty, at which point CritiCool® system can be powered down. <p>Emptying is also described on page 61.</p>
	 <p style="text-align: center;">Figure 44: Male Draining Connector Attached to Connecting Water Hoses (for Emptying)</p>

Table 15: CritiCool System Technical Alarm Messages Troubleshooting Guide



Message	Cause of Problem	Action to be taken	Comments
 Indicates that an alarm is activated			
Tank is Empty 	No water in the tank. Water tank float is jammed.	Open water tank cap. Refill water tank to maximum level. Insert a long object to release the float.	
Add Water 	Water level is too low.	Refill water tank to maximum.	The alarm can be muted for an unlimited time.
Connect Water Tubes 	Connecting tubes are not connected.	Connect connecting tubes, listening for the click. Check for creases, folds, or objects that obstruct the water flow in the wrap. Check clamps.	Pressing alarm mute silences the buzzer for 30 minutes.

Table 16: CritiCool System Technical Alarm Messages Troubleshooting Guide

Message	Cause of Problem	Action to be taken	Comments
<p>Connect Core Sensor</p> 	<p>No core temperature probe is inserted in its socket.</p>	<p>Connect core temperature probe.</p>	<p>Pressing alarm mute silences the buzzer for 30 minutes.</p>
<p>Check Water Tubes</p> 	<p>Wrap is blocked due to improper wrapping.</p> <p>Wrap clamps are closed.</p>	<p>Check for creases, folds, or objects that obstruct the water flow in the wrap.</p> <p>Check clamps.</p>	<p>Pressing alarm mute silences the buzzer for 30 minutes.</p>
<p>Check Core Sensor</p> 	<p>Misplacement of core temperature probe in core socket.</p> <p>Core temperature probe's adapter is connected to the CritiCool® without the temperature probe.</p>	<p>Connect the core temperature probe to the appropriate socket.</p> <p>Connect disposable temperature probe to the adapter cable and insert into the patient.</p> <p>After repositioning probe, check that on screen values are valid.</p>	<p>This alarm cannot be muted.</p>

Table 17: CritiCool System/Clinical Messages Troubleshooting Guide

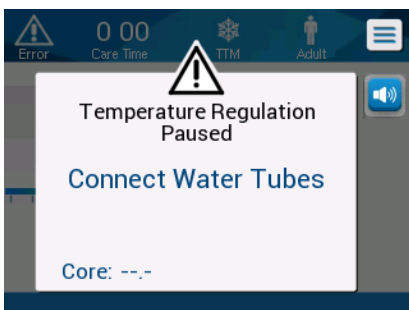

Message	Cause of Problem	Action to be taken	Comments
Water Temperature Too Low 	Water temperature in the system is less than 10°C (50°F).	Thermoregulation stops. Turn OFF the system for 3 seconds and then turn it ON again. If the problem persists, turn OFF CritiCool® and contact a Belmont Medical Technologies representative.	The alarm can be muted for unlimited time.
Water Temperature Too High 	Water temperature in the system is more than 42°C (107.6°F).	Thermoregulation stops until the water cools or the system halts. Turn OFF the system for 3 seconds and then turn it ON again. If the problem persists, turn OFF CritiCool® and contact a Belmont Medical Technologies representative.	The alarm can be muted for an unlimited time.
Switching to AutoRewarm Mode 	Confirmation of the patient's core temperature before changing to Controlled Rewarming mode.	Confirm the patient's temperature. Once confirmed, press OK to continue.	The Rewarming Virtual Set Point will be calculated based on the temperature when OK is pressed. This alarm cannot be muted. See page 67.

Table 18: CritiCool “Core Readout Too Low” Safety Message Troubleshooting Guide

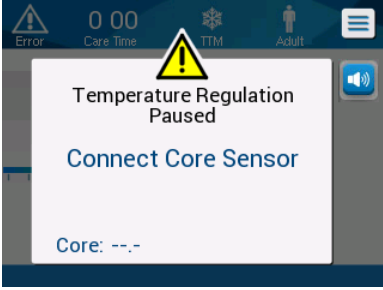
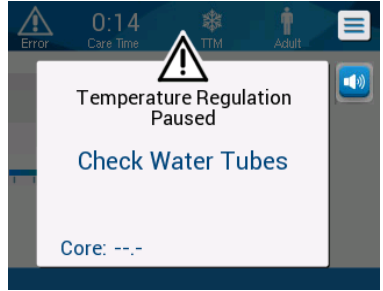
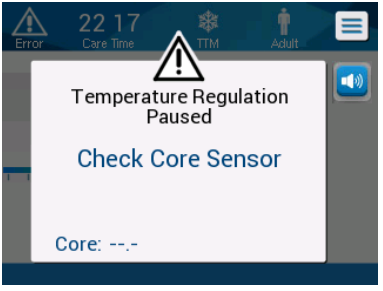
Message	Cause of Problem	Action to be taken	Comments
<p>Core Readout Too Low</p> 	<i>TTM Mode and Controlled Rewarming Mode:</i>		
	<p>Core temperature is at least 2°C lower than Set Point – or the core temperature is below 30.8°C.</p> <p>The core probe may have partially or fully dislodged.</p>	<p>Confirm the location of the core temperature probe.</p> <p>Compare the core value against the surface value to confirm the values are accurate.</p> <p>Always confirm the core probe before pressing OK.</p>	<p>An alarm sounds, thermoregulation stops, and water flow also stops if 1) in Neonatal Mode, or 2) if in TTM and Adult Mode and core temperature is below 30.8°C.</p> <p>The alarm can be muted for 5 minutes.</p> <p>NOTE: If you disregard the message and do not touch OK for over 30 minutes, the alarm cannot be silenced until the OK button is touched.</p> <p>When OK is touched, the screen returns to the Main Screen and a message appears for 5 seconds indicating that thermoregulation has resumed.</p> <p>See page 78.</p>
	<i>Controlled Rewarming Mode only:</i>		
<p>Rewarming is too slow for the selected rewarming rate.</p>	<p>Same as above.</p>	<p>See page 81.</p>	

Table 19: CritiCool System Messages (Notes) (v6.4 Only) Troubleshooting Guide

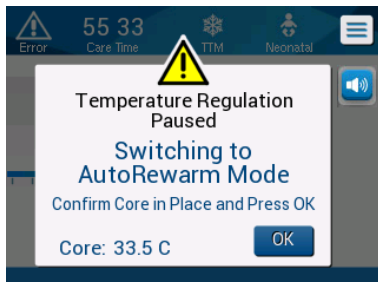

Message	Cause of Problem	Action to be taken	Comments
<p>Patient Mode Changed. Check Set Point.</p> 	<p>The patient mode has been changed in Settings, which automatically adjusts the Set Point temperature.</p>	<p>Confirm Set Point and adjust if needed using the set point key.</p>	<p>This message displays for 30 seconds.</p> <p>This message only displays in Software Version 6.4.</p> <p>See page 49 for more information.</p>
<p>Holding Core Temperature for First Step of Rewarming</p> 	<p>This message appears upon initiating Controlled Rewarming Mode after the Switching to “Auto Rewarm” message appears.</p>	<p>Follow the patient’s temperature.</p>	<p>In Software Version 6.4, core temperature is maintained for the first rewarming step, which lasts from 0.5 to 2.0 hours, and this message displays for 30 minutes.</p> <p>This message only displays in Software Version 6.4.</p> <p>See page 70 for more information.</p>
<p>Target Temperature Has Been Reached</p> 	<p>This message displays in Controlled Rewarming Mode when the core temperature reaches Target Temperature.</p>	<p>Inform the clinician.</p> <p>If continuing thermoregulation initiate Normothermia Mode via Mode Select.</p> <p>Consult page 71.</p>	<p>This message displays for 30 minutes.</p> <p>This message only displays in Software Version 6.4.</p> <p>See page 71 for more information.</p>

Table 20: CritiCool Clinical Messages (Notes) Troubleshooting Guide

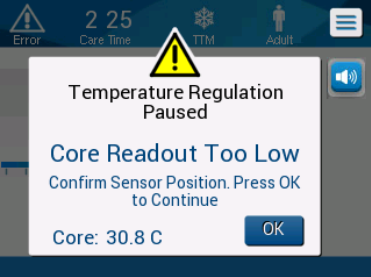

Message	Cause of Problem	Action to be taken	Comments
<p>Low Core Temperature Thermoregulation is Continuing.</p> 	<p>This message appears:</p> <p>When core temperature is $>0.8^{\circ}\text{C}$ and yet $<2.0^{\circ}\text{C}$ less than the Set Point.</p>	<p>Check core temperature probe is in place and keep following the patient's temperature.</p> <p>No other action is required.</p> <p>If rewarming manually: Do not attempt to increase more than 0.8°C above actual core temperature.</p>	<p>An alarm sounds but thermoregulation continues.</p> <p>The message on the screen will disappear once the patient reaches within 0.6°C of set point.</p> <p>The alarm can be muted for 30 minutes.</p> <p>See page 78.</p>
<p>Patient Temperature is Below XX.X°C</p> 	<p>The alarm for Low Patient Temperature can be configured in "Settings". The alarm and message are issued according to the selected alarm limit. The available values are: 31°C, 32°C, 33°C, 34°C, 35°C, and 36°C.</p>	<p>Check that the core temperature probe is in place and follow the patient's temperature.</p> <p>Inform the clinician.</p>	<p>An alarm sounds but thermoregulation continues.</p> <p>The alarm can be muted for 30 minutes.</p>
<p>Out of Normothermia Range</p> 	<p>Appears when a set point temperature $<36.0^{\circ}\text{C}$ or $>38.0^{\circ}\text{C}$ is chosen.</p>	<p>Touch OK to confirm the new Set Point temperature and eliminate the message.</p>	<p>Thermoregulation continues.</p>

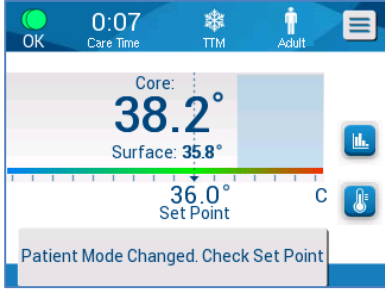
Table 21: CritiCool Clinical Messages (Notes) Troubleshooting Guide

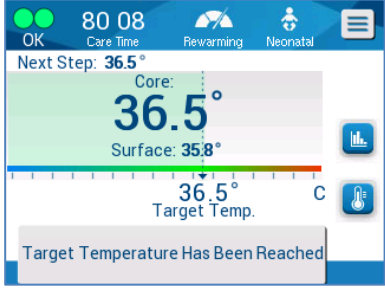
Message	Cause of Problem	Action to be taken	Comments
<p>Patient Temperature is Above XX.X°C</p> 	<p>The alarm for High Patient Temperature can be configured in “Settings”. The alarm and message are issued according to the selected alarm limit.</p> <p>The available values are: 36°C, 36.5°C, 37°C, 37.5°C, 38°C, and 38.5°C.</p>	<p>Check that the core temperature probe is in place and follow the patient’s temperature.</p> <p>Inform the clinician.</p>	<p>An alarm sounds but thermoregulation continues.</p> <p>The alarm can be muted for 30 minutes.</p>
<p>Body Temperature in Accepted Range</p> 	<p>CritiCool has left an alarm state and returned to a normal operation mode and core temperature has reached set point.</p>		<p>The message appears for 5 seconds.</p>
<p>Thermoregulation is Continuing.</p> 	<p>CritiCool has left an alarm state and returned to a normal operation mode.</p>	<p>Confirm patient’s temperature.</p>	<p>The message appears for 5 seconds.⁷⁸</p>

Chapter 8: Clinilogger™ Installation And Operating

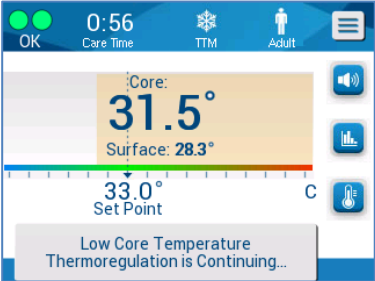
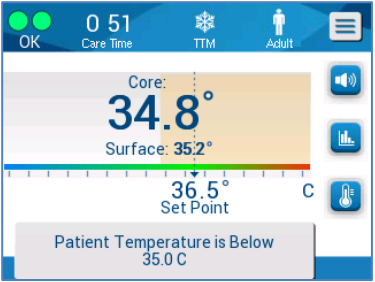
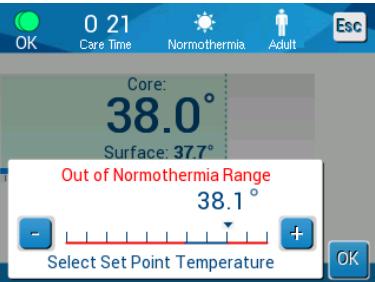
Instructions

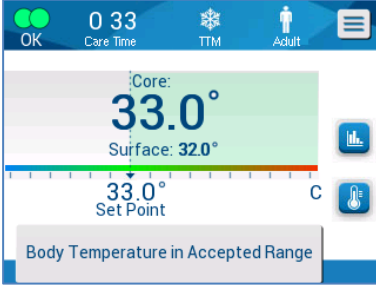
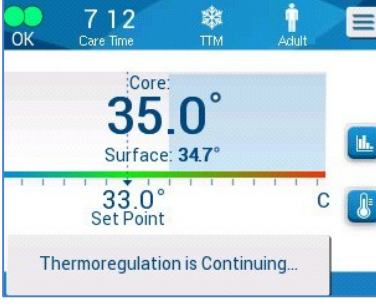
Overview and Installation

Introduction

The purpose of the optional Clinilogger™ device is to save the CritiCool® / CritiCool® MINI / Allon® systems' vital data for further reference. For more information on connecting the Clinilogger to CritiCool for data collection, see on page 33.

By means of the Clinilogger™ Viewer software, the user can use an external PC to review this saved data.

Using the Clinilogger™ Application

The Clinilogger™ device connects to the RS-232 (serial) connector in the rear of the CritiCool® for data transfer. While the device is connected, **data is saved at each one-minute interval.**

Connect the Clinilogger™ device to the CritiCool® before the start of the medical procedure.

Belmont Medical Technologies recommends recording CritiCool® device data for one patient at a time. At the end of the procedure, disconnect the Clinilogger™ device from the thermoregulation machine and connect to a PC. Download the data from the device and then reconnect the Clinilogger™ to the thermoregulation machine so it is ready for the next procedure.

The Clinilogger™ Software

The Clinilogger™ device is supplied with a Clinilogger™ Viewer software CD to be installed on a PC for downloading and viewing the saved data from the CritiCool®. Alternatively, to download the software online, request the link from the Belmont technical service team at techservice@belmontmedtech.com.

Installing the Software

To install the Clinilogger™ software:

1. On your PC, double-click on **My Computer** and open the CD drive.
2. Double-click the **Installer** folder.
3. Double-click the **Volume** folder
4. Double-click **setup**; the Clinilogger™ install window appears.

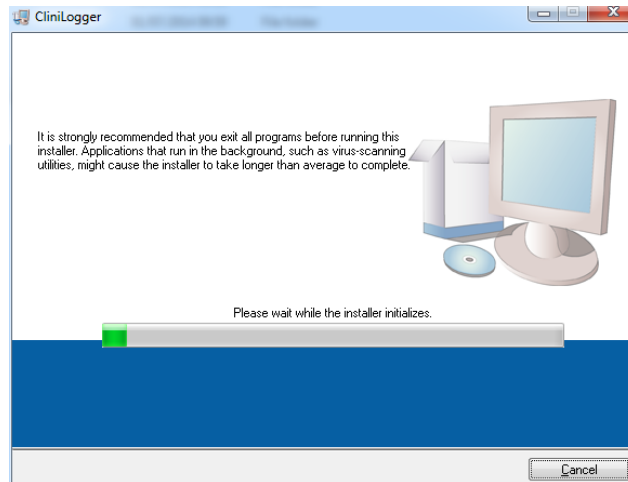

Figure 45: ClinILogger™ Initialization

When initialization finishes the following screen appears.

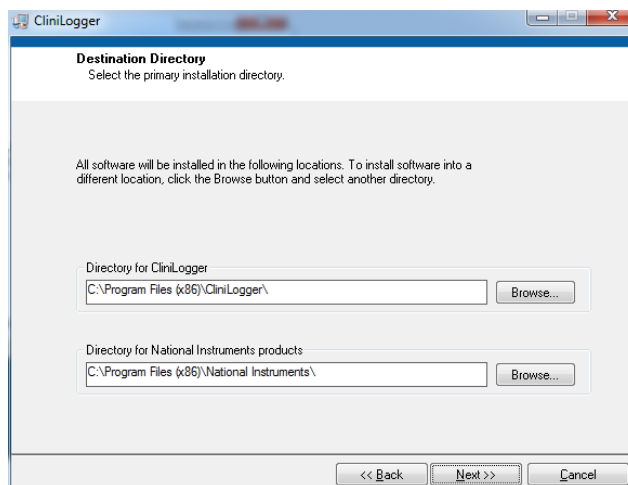

Figure 46: ClinILogger™ Installation

5. You can change the installation location by clicking **Browse** and selecting a new location. Click **Next**. **The License Agreement window appears.**
6. Select **I accept the above License Agreement(s)** to accept the license agreements and click **Next**. The Start Installation window appears.

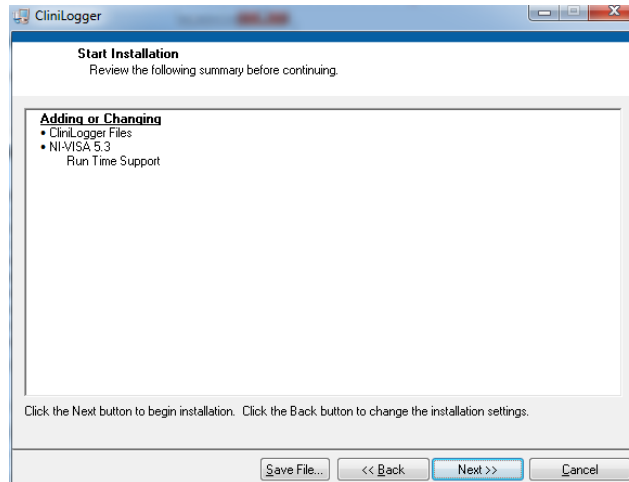

Figure 47: Start Installation

7. Click **Next**; you can follow the installation progress in the progress bars until it finishes.

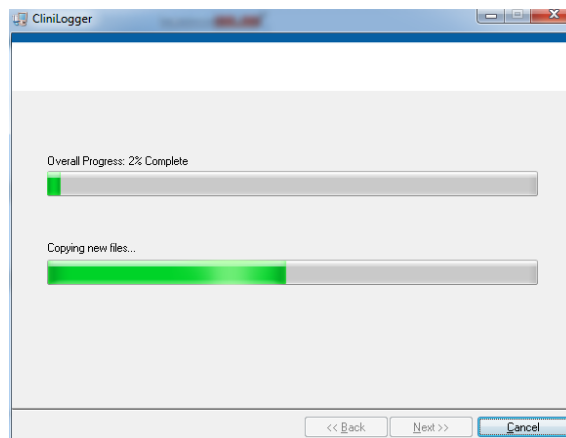

Figure 48: Installation Progress

When the installation is finished, the **Installation Complete** window appears:

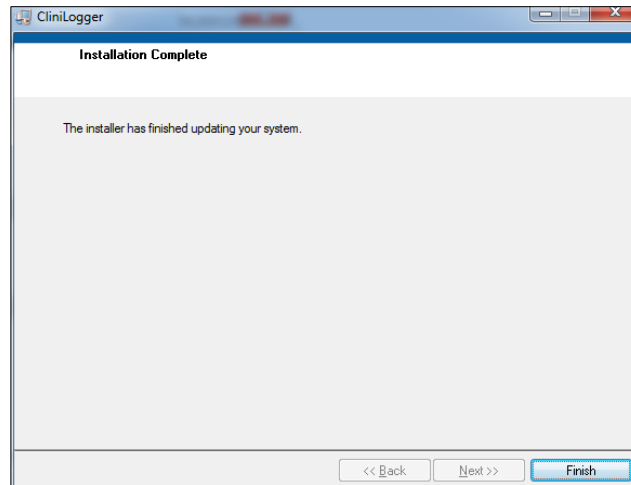

Figure 49: Installation Complete

8. Click **Finish** to complete and exit the software installation.
9. Copy "User Ver 1.6" folder from CD to your desktop.
10. You can now open "User Ver XX." folder and click the Clinilogger.exe file to start the application.

Using the Clinilogger™ Viewer Application

Downloading Data

You can download data from the Clinilogger™ Device to the Clinilogger™ Viewer Application on the PC.

To start the CliniLogger™ application:

1. From the Windows *Start* menu, click Programs > CliniLogger.
2. Click on the CliniLogger™ icon; the CliniLogger™ window appears.

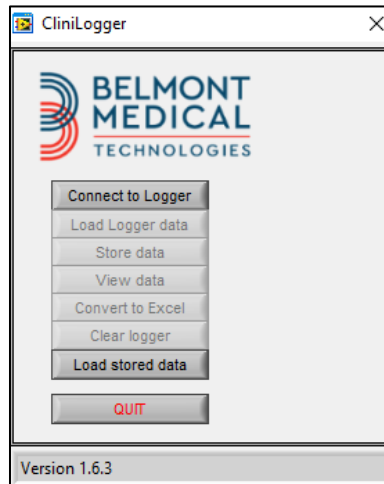

Figure 50: CliniLogger™ Application Window

3. Connect the CliniLogger™ device to the serial COM1 port of the PC.

NOTE: *Verify that the CliniLogger™ device is connected to the COM 1 –10 port or you can use with USB to RS232 adaptor.*

6. Click **Connect to Logger**, the software traces the COM port where the CliniLogger™ is connected – wait for the **Connected** message.
7. Click **Load Logger data**, wait for the **Complete** message.
8. Click **Store data** and choose a file and a location.
9. Click **View data**; the graph opens.
10. You can also click **Convert to Excel** to present the data in Excel format.
11. Click **Clear logger** after saving the data to prepare the device for the next use.

IMPORTANT! *You should erase the data on the CliniLogger™ manually after each patient. Otherwise, the CliniLogger™ continues to burn data from the earliest patient.*

Viewing Downloaded Data

To view downloaded data:

1. Double-click the CliniLogger™ Viewer icon. The CliniLogger™ window appears.

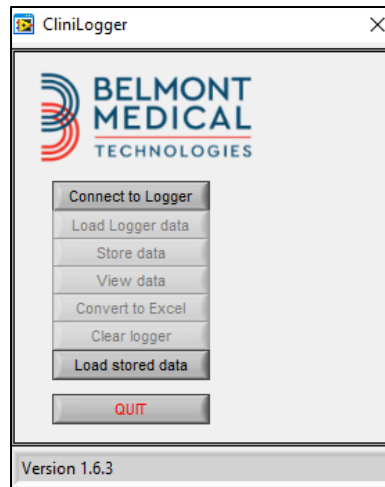

Figure 51: CliniLogger™ Window

2. Click Load stored data and choose the file you would like to view.

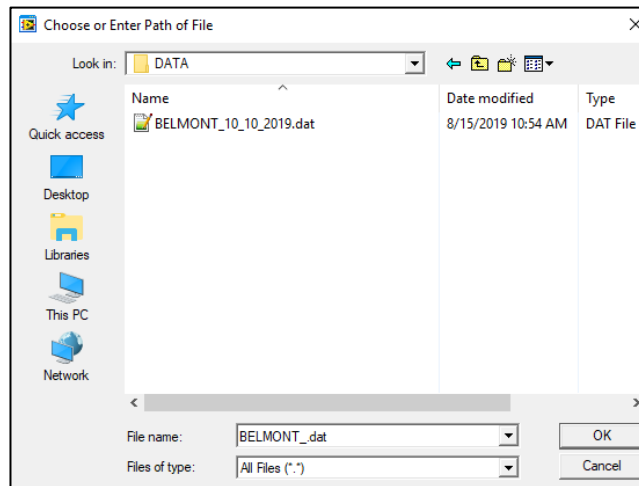

Figure 52: Choose CliniLogger™ File Window

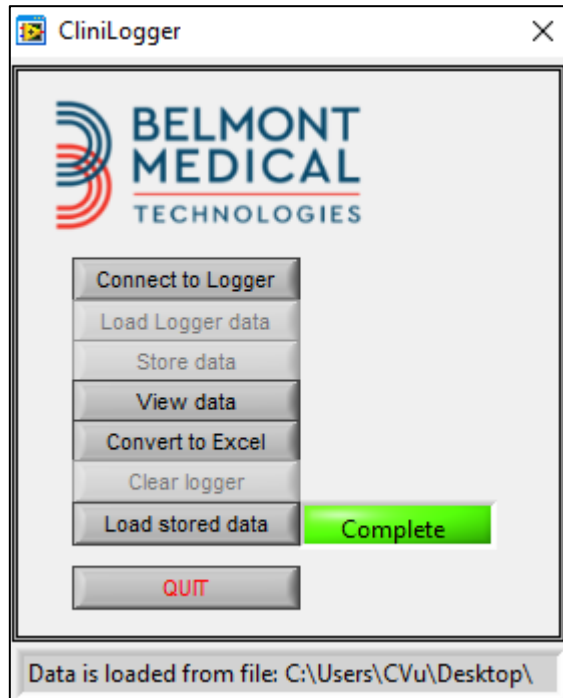

Figure 53: Complete Message

When the data has been loaded the “Complete” message appears

3. Click **View data** - the graph opens.
4. To convert to Excel, click **Convert to Excel** – the data is presented in Excel format.

CliniLogger™ Viewing Panel

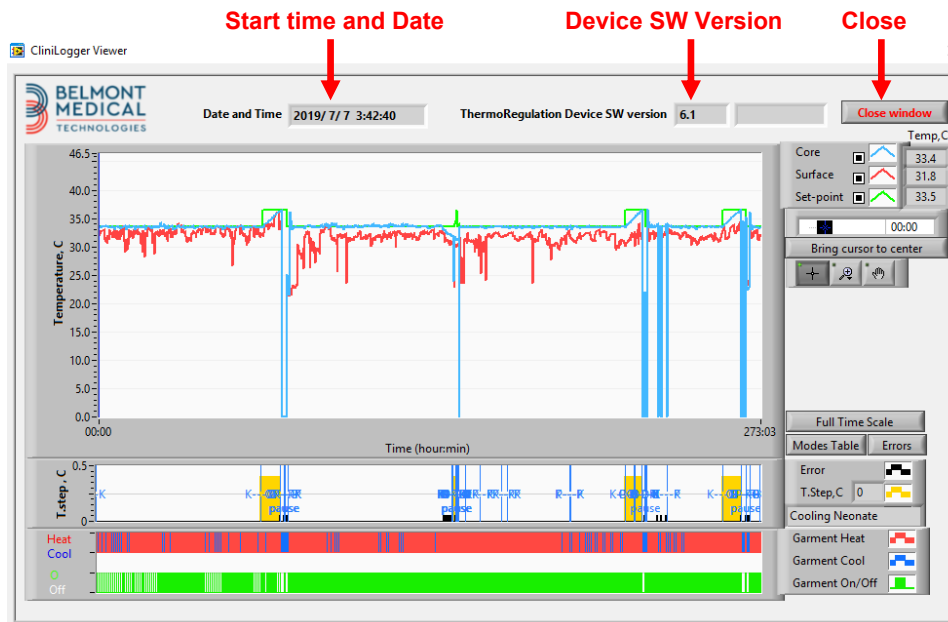

Figure 54: CliniLogger™ Viewing Panel

The CliniLogger™ viewing panel includes the following data:

- **Start date and time** received from the thermoregulation device (CritiCool®)
- **Software version** of the thermoregulation device
- **Close Window** button
- Function Selection area: control keys
- Graphic Display area with a graphic presentation of the thermoregulation system variables.

Graphic Display Area

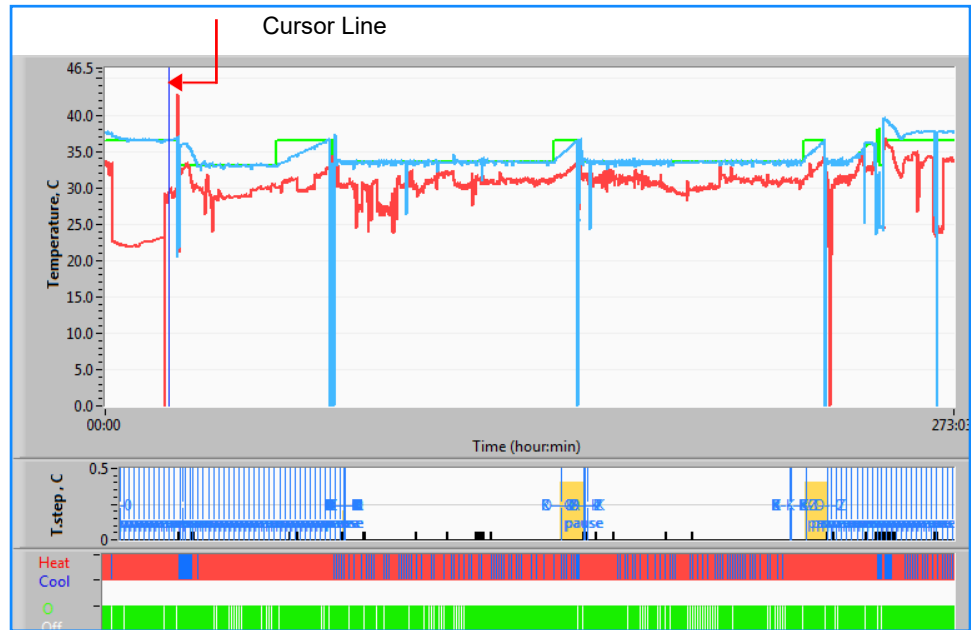

Figure 55: Graphic Display Area

The Graphic Display area consists of three parts:

- **Temperatures graphs:** Set-point, Core and Surface as a function of time
- **Modes and Error area:** Thermoregulation modes, Rewarming step and errors as a function of time
- **Device Functional Status area:** Heat/Cool and Pump On/Off

Function Selection Area

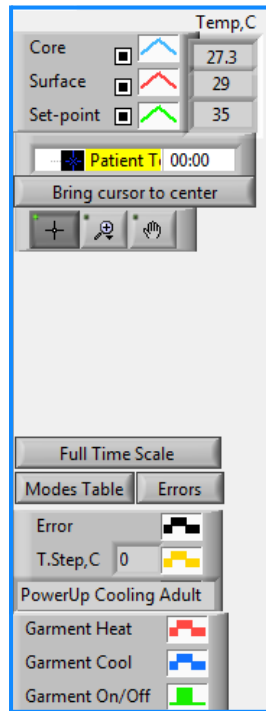
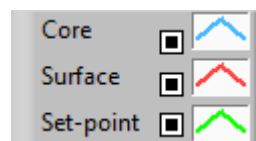

Figure 56: Example: Functional Status Area

The Function Selection area includes the keys that provide the ability to modify the Graphic Display area, such as zooming in and out, moving between time zones and detailing the viewed data.

Temperature Graph Control Buttons

These buttons define the shape of the curves in the temperature graphs area, the water heat/cool graph and the water flow graph.



Temperature Settings

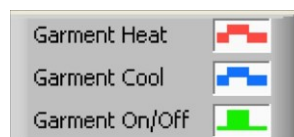

Wrap Settings

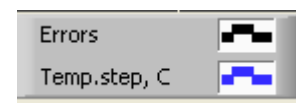

Errors/TempStep Settings

Figure 57: Example: Modes and Errors Area

Temperature graph control buttons enable modifying the display of each of the temperature graphs.

Display / Hide Buttons

Use the temperature setting toggle buttons to Display / Hide each of the temperature graphs.

Color Buttons

These buttons allow for changing the graph features and colors.

NOTE: *It is recommended to keep the default settings.*

View Manipulation Buttons

A set of three buttons is shown under the temperature buttons



Hand - Click the Hand  button, using the mouse move the hand cursor to the temperature graph area; and “grab” the curve by pressing the mouse left button and moving the mouse.

Moving the mouse horizontally will move the graphs horizontally - in time, and moving the mouse vertically, will move the graphs vertically - in temperature.

Zoom Clicking the Zoom button shows 6 modes of zoom use:

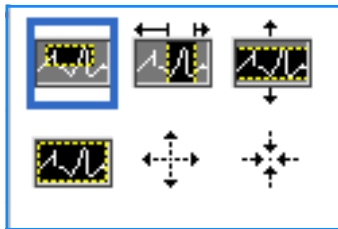









Table 22: Zoom Tool Buttons

Button	Click to...	How to use...
	return the graphs to the default (un- zoomed) display	
	zoom out symmetrically in X and Y directions	Click this zoom tool button. Using the mouse move the cursor to the Temperature graph; the cursor image changes to the button icon. Click the mouse to zoom out. You can click again to zoom out again.
	zoom in symmetrically in X and Y directions	Click this zoom tool button. Using the mouse move the cursor to the Temperature graph; the cursor image changes to the button icon. Click the mouse to zoom in. You can click again to zoom in again.
	create an XY zoom in box.	Click this zoom tool button. Using the mouse move the cursor to the Temperature graph; the cursor image changes to zoom icon. Press the left mouse button and select the box in the graph for zooming in. Once you release the mouse button the image is zoomed in.
	zoom in, in the X (Time) direction.	Click this zoom tool button, using the mouse move the Zoom tool cursor to the required point of time, click to insert the low limit line, keep the left key pressed and pull horizontally to the end of the time period desired. Once you release the mouse button the image is zoomed in.
	zoom in, in the Y (Temperature) direction.	Use the mouse move the Zoom tool cursor to the lower temperature limit, click to insert the low limit line, keep the left key pressed and pull vertically. Release the key to view the temperature graphs zoomed in the selected vertical area.

To return to full time scale after zoom actions:

1. Click on .

The graph returns to the full-time range, without affecting the Temperature scale.

NOTE: To return to the original display click the unzoom button .

Cursor Line

The values of the temperatures at the cursor line location appear in the window adjacent to the curve color window (see [Figure 54](#)).

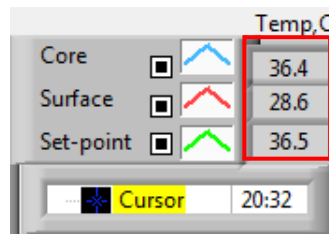



You can change the time of the Cursor Line on the graph (see [Figure 54](#)).

To set the time of the cursor:

1. Use the keyboard to set the required time in the **Cursor** textbox. Make sure to select the time as displayed on the graph (and in the HH:MM format).
2. Press ENTER.

The cursor moves to the selected time spot and the Temperatures displayed are the temperatures of the new spot.

To move the cursor line, in time (X direction)

5. Click the Cursor  icon.
6. Bring the + to the cursor location, the + will convert to a double line
7. Use the mouse to move the double line to a new cursor location. 

NOTE: *The values of the temperature at the cursor location appear in the window adjacent to the curved color window*

Modes and Error Area

This area provides the following information:

System mode marked by letters (See Figure 58) and a vertical line.

Rewarming steps between 0°C and 0.5°C shown in the example in pink (the step was first 0.4°C and then changed to 0.2°C).

Error: Period with no control, in the example due to system pause (yellow markings).

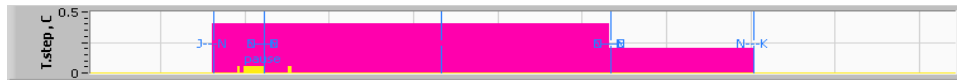

Figure 58: Example of Modes and Error Area

Table 23: CliniLogger Mode Codes

Code	Indicates		
A	PowerUp	Cooling	Adult
B	PowerUp	Cooling	Neonate
C	PowerUp	Warming	Adult
D	PowerUp	Warming	Neonate
E	PowerUp	Rewarm	Adult
F	PowerUp	Rewarm	Neonate
G	PowerUp	Standby	
H	PowerUp	Sel.Mode	Adult
I	PowerUp	Sel.Mode	Neonate
J	Cooling	Adult	
K	Cooling	Neonate	
L	Warming	Adult	
M	Warming	Neonate	
N	Rewarming	Adult	
O	Rewarming	Neonate	
P	Standby		
Q	Select Mode		Adult
R	Select Mode		Neonate

Functional Status Area – Heat/Cool and Pump On/ Power Off

The graphs indicate the state of the wrap: **Heat / Cool** modes and the **On/Off of water circulation** in the wrap.

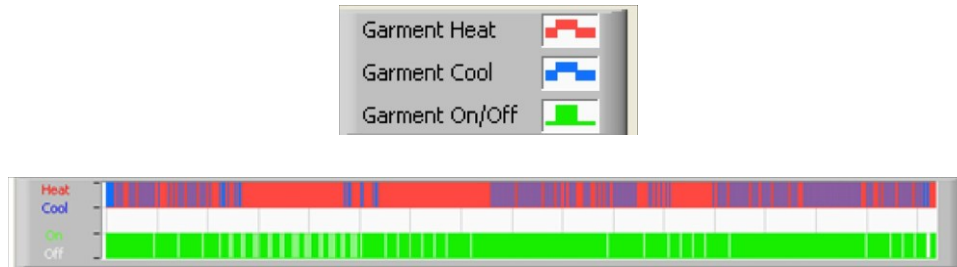

Heat/Cool- When CritiCool® is cooling the water in the tank, the line is blue. When the device is warming the water in the tank, the line is red.

Pump On/Off- When the pump is pumping water into the Wrap, the line is green. When CritiCool® is circulating the water internally (i.e. in "Standby mode"), the line is white.

Converting to Excel

To convert to Excel:

1. On the CliniLogger™ menu panel (see [Figure 8-6](#)) select **Convert to Excel**; an Excel file opens with two options:

Measurement Table (Sheet 1)

	A	B	C	D	E	F	G
1	Date&Time	Record Time	Core	Surface	Set-Point	Mode	Errors
1161	2023/ 8/29 16:20:12	19:19	33.6	32.9	33.5 K		
1162	2023/ 8/29 16:21:32	19:20	33.6	32.9	33.5 K		
1163	2023/ 8/29 16:22:32	19:21	33.6	32.9	33.5 K		
1164	2023/ 8/29 16:23:32	19:22	33.6	32.9	33.5 K		
1165	2023/ 8/29 16:24:32	19:23	33.6	32.9	33.5 K		
1166	2023/ 8/29 16:25:32	19:24	33.6	32.9	33.5 K		
1167	2023/ 8/29 16:26:22	19:25	33.6	32.9	33.5 K		
1168	2023/ 8/29 16:26:52	19:26	33.6	32.8	33.5 K		
1169	2023/ 8/29 16:28:32	19:27	33.6	33	33.5 K		
1170	2023/ 8/29 16:29:32	19:28	33.5	33.1	33.5 K		
1171	2023/ 8/29 16:30:32	19:29	33.6	33.1	33.5 K		
1172	2023/ 8/29 16:31:32	19:30	33.6	33.1	33.5 K		
1173	2023/ 8/29 16:32:32	19:31	33.6	33.2	33.5 K		
1174	2023/ 8/29 16:33:32	19:32	33.6	33.2	33.5 K		
1175	2023/ 8/29 16:34:32	19:33	33.6	33.3	33.5 K		
1176	2023/ 8/29 16:35:22	19:34	33.6	33.4	33.5 K		
1177	2023/ 8/29 16:36:22	19:35	33.6	33.4	33.5 K		
1178	2023/ 8/29 16:37:32	19:36	33.5	33.4	33.5 K		
1179	2023/ 8/29 16:38:32	19:37	33.5	33.4	33.5 K		
1180	2023/ 8/29 16:39:27	19:38	33.5	33.5	33.5 K		

Figure 59: Section of Excel Table

Graphic Chart

A second page in the Excel file shows a graphic description of the Excel table with the Y axis showing the temperatures, and the X axis the Excel table lines.

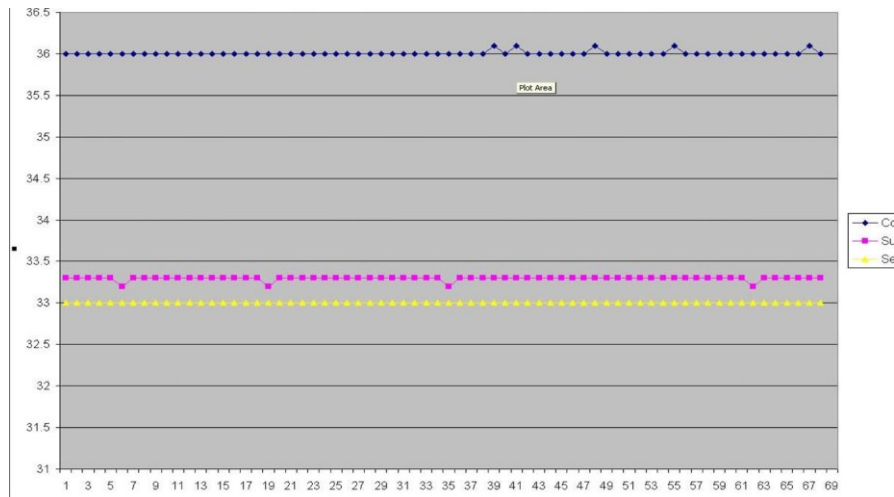

Figure 60: Section of Graphic Chart

Ending a Viewing Session

To end a session:

Click **Quit** on the Main Menu to exit the Viewing Session.

Appendix A: EMI / EMC Information

WARNING!

Medical Electrical Equipment needs special precautions regarding EMC and needs to be installed and put into service according to the Electromagnetic Compatibility [EMC] information provided in the accompanying documents.

WARNING!

Portable RF communications equipment should be used no closer than 30 cm to any part of the device, otherwise degradation of the performance of this equipment could result

NOTE:

The EMC tables and other guidelines that are included in the Operators Manual provide information to the customer or user that is essential in determining the suitability of the Equipment or System for the Electromagnetic Environment of use, and in managing the Electromagnetic Environment of use to permit the Equipment or System to perform its intended use without disturbing other Equipment and Systems or non-medical electrical equipment.

The essential performance features of CritiCool are the accuracy of the temperature measurement system, the water temperature control, alarms if core temperature is unexpected, and halt conditions in case that any of the elements of the control mechanism fail.

Table 24: Guidance and Manufacturer's Declaration – Emissions

CritiCool® is intended for use in the electromagnetic environment specified below. The customer or user of CritiCool® should assure that it is used in such an environment.		
Emissions Test	Compliance	Electromagnetic Enforcement – guidance
RF Emissions CISPR 11	Group 1, Class A	The device should not be stacked with other equipment. Use of accessories and cables other than those specified by Belmont could result in increased electromagnetic emissions or decreased electromagnetic immunity of this equipment and result in improper operation.
Harmonics IEC 61000-3-2	Class A	Complies
Flicker IEC 61000-3-3	Complies	Complies

Table 25: Guidance and Manufacturer's Declaration – Immunity

<p>CritiCool® is intended for use in the electromagnetic environment specified below. The customer or user of CritiCool® should assure that it is used in such an environment.</p>	
Immunity Test	IEC 60601 Passed Parameters
IEC 61000-4-2 Electrostatic Discharge (ESD)	±8kV contact ±15kV air
IEC 61000-4-3 Radiated RF	3 V/m 80MHz-2.7GHz 80% AM @ 1kHz
IEC 61000-4-3 Proximity field Immunity	385 MHz at 27 V/m, 18 Hz Pulse Modulation 450 MHz at 28 V/m, 1 kHz Frequency Modulation ± 5 kHz Dev 810 MHz, 870 MHz, and 930 MHz at 28 V/m, 18 Hz Pulse Modulation 710 MHz, 745 MHz, and 780 MHz at 9 V/m, 217 Hz Pulse Modulation 1720 MHz, 1845 MHz, 1970 MHz, and 2450 MHz at 28 V/m, 217 Hz Pulse Modulation 5240 MHz, 5500 MHz, and 5785 MHz at 9 V/m, 217 Hz Pulse Modulation
IEC 61000-4-4 Electrical Fast Transient/burst	±2kV on AC Mains 100kHz Repetition frequency
IEC 61000-4-5 Surge	±1kV Line-to-line ±2kV Line-to-earth
IEC 61000-4-6 Conducted RF	3 Vrms from 150 kHz to 80 MHz 6Vrms in ISM bands between 0.15 MHz and 80 MHz 80% AM @ 1 kHz
IEC 61000-4-8 Power Frequency 50/60Hz Magnetic Field	30A/m
IEC 61000-4-11 Voltage dips, short interruptions, and voltage variations on power supply input lines	100% Dip for 0.5 Cycle @ 0°, 45°, 90°, 135°, 180°, 225°, 270°, and 315° 100% Dip for 1 Cycle 30% Dip for 25 Cycles 100% Dip for 5 Seconds

Appendix B: Waste Electrical & Electronic Equipment (WEEE)

The crossed-out wheel bin symbol on the product, literature, or packaging reminds you that all electrical and electronic products, batteries, and accumulators must be taken to separate collection at the end of their working life. This requirement applies to the European Union and other locations where separate collection systems are available. To prevent possible harm to the environment or human health from uncontrolled waste disposal, please do not dispose of these products as unsorted municipal waste, but instead, hand in at an official collection point for recycling.