

CritiCool® MINI User Manual





Conformity According To The Council Directive 93/42/EEC As Amended By 2007/47/EC



Belmont Medical Technologies
780 Boston Road
Billerica, MA 01821 USA
Technical Service
885-397-4547 (USA)
+1-978-663-0212 (WORLDWIDE)
www.belmontmedtech.com



Emergo Europe
Westervoortsedijk 60
6827 At Arnhem
The Netherlands



Medenvoy Switzerland
Gotthardstrasse 28
6302 ZUG
Switzerland

The user manual and translations are available by digital version:



1) Visit the Belmont website under Resources:

<https://belmontmedtech.com/resources>

2) Scan the QR code to the left.

To request a printed or previous version of a user manual, please contact:

resources@belmontmedtech.com

RIGHTS RESERVED

Registered trademarks are the intellectual property of their respective holders.

Use of Manual

The purpose of this manual is to help medical personnel understand and operate the system. It is important that you read this manual and familiarize yourself thoroughly with its contents before you attempt to operate the system. If you do not understand any part of this manual, or if anything is unclear or ambiguous in any way, please contact your Belmont Medical Technologies representative for further clarification.

The CritiCool® MINI system described in this manual has been designed to meet international safety and performance standards. Only trained medical personnel may operate the system. These operators must first have a full understanding of the proper operation of the system.

The information provided in this manual is not intended to replace regular medical training procedures.

This manual should always accompany the system. All qualified personnel operating the system should know the location of the manual. For additional copies of this manual, please contact your Belmont Medical Technologies representative.

Training

Belmont Medical Technologies or its authorized distributor will provide training for the system user according to the intended use of the device or system.

It is the responsibility of the hospital management to ensure that only users trained to use the equipment safely, operate the equipment.

Operator Profile

Connections and device settings should be performed by a clinical expert in thermoregulation.

Important Notice

No part of this manual may be reproduced or copied in any form by any graphic, electronic, or mechanical means - including photocopying, scanning, typing or information retrieval systems - without advanced written permission from Belmont Medical Technologies.

Disclaimer

NOTE: *All instructions regarding the reusable temperature probes are not applicable for the USA and other select markets.*

Belmont Medical Technologies is not responsible for any consequential or incidental damages or expenses of any kind, impairment of or damage to other goods caused by the following:

- a. Installed, operated, maintained contrary to Belmont Medical Technologies' instructions, notes or warnings under this manual.
- b. Ignoring any of the warnings, precautions and safety measures indicated in this manual.
- c. Replacement, repair or altering not performed by Belmont Medical Technologies' authorized personnel.
- d. The use of accessories and other parts or equipment made by other manufacturers, whether or not warranted by such manufacturers, which have been attached or connected to the system after installation, unless such accessories and other parts have been supplied and attached or installed by Belmont Medical Technologies.
- e. Using the system in a contrary manner than indicated in this manual or using the system for any purpose other than indicated in the manual.

Table Of Contents

Use of Manual	3
Chapter 1: Safety Precautions	9
Definitions	9
Intended Use.....	9
Warnings	9
Precautions	10
EMC Safety	10
Improper Use	10
Labels.....	11
Chapter 2: System Description	14
CritiCool® MINI System.....	14
CritiCool® MINI Device	14
CritiCool® MINI Battery	15
Power Cable Connection	15
Grounding The System.....	15
Warnings.....	15
External Features.....	16
Garment/Wrap.....	18
Reusable Temperature Probes.....	20
Disposable Temperature Probes.....	21
Chapter 3: Installation	27
Pre-Installation Requirements.....	27
Chapter 4: Operating Instructions	29
CritiCool® MINI Functions	29
Controls, Functions, Indicators and Connections	29
Patient Thermoregulation – Step by Step Operation.....	33
Operating the System	34
Services	59
Empty	60
Replacing the Wrap	61
Operation Panel Messages and Alerts	62
Safety Messages and Alarms	63
Clinical Messages and Alarms.....	64
Technical Messages and Alerts.....	66
Controlled Rewarming Mode Messages.....	72
Chapter 5: Ordering Information	74
Equipment and Accessories	74
Available Wraps	74
Available Accessories	75
Chapter 6: Maintenance	77
Introduction	77
Service Information.....	77
Routine & Preventative Maintenance	78
Routine Maintenance Overview.....	78
Cleaning & Disinfecting External Surfaces	79
Cleaning, Disinfecting and Sterilization of the Reusable Temperature Probes.....	80
Water Circuit Disinfection Instructions	81

Thermal Disinfection Process (Self-Cleaning).....	85
System Check Service.....	86
Filter Replacement.....	88
Chapter 7: Troubleshooting.....	89
General.....	89
Troubleshooting Guide.....	89
Chapter 8: CliniLogger™ Installation and Operating Instructions.....	98
Overview and Installation.....	98
Using the CliniLogger™ Viewer Application.....	102
Viewing Downloaded Data.....	103
CliniLogger™ Viewing Panel.....	105
Graphic Display Area.....	106
Function Selection Area.....	107
Appendix A: EMI / EMC Information.....	114
Appendix B: Waste Electrical & Electronic Equipment (WEEE).....	116

List Of Figures

Figure 1: Label Placement For The CritiCool® MINI Device.....	11
Figure 2: Front View.....	16
Figure 3: Rear View.....	17
Figure 4: Disposable Temperature Probes Connection.....	21
Figure 5: Self-Test Screen.....	34
Figure 6: Halt Error.....	34
Figure 7: Select Mode Upon Startup.....	38
Figure 8: Main Screen.....	38
Figure 9: Control Panel.....	39
Figure 10: Main Menu.....	40
Figure 11: Standby.....	41
Figure 12: Select Mode Panel.....	42
Figure 13: TTM Mode.....	43
Figure 14: Selecting a Rewarming Step.....	44
Figure 15: Rewarming Step on the Main Screen.....	45
Figure 16: Select Mode - Controlled Rewarming.....	46
Figure 17: Switching to Rewarming Mode.....	47
Figure 18: Low Core Temperature.....	48
Figure 19: Temperature Regulation Paused Message.....	48
Figure 20: Target Temp.....	49
Figure 21: Target Temperature Setting Panel.....	49
Figure 22: Holding Core Temp for First Step of Rewarming.....	50
Figure 23: Target Temperature Has Been Reached.....	51
Figure 24: Temperature Regulation Paused Message.....	52
Figure 25: Out of Normothermia Message.....	54
Figure 26: Settings Screen 1.....	55

Figure 27: Settings Screen 2	55
Figure 28: Settings Screen 3	56
Figure 29: Settings Screen 4	56
Figure 30: Main Panel with System ID	56
Figure 31: Set-Point Setting Screen	57
Figure 32: Temperature Graph	58
Figure 33: Select Service.....	59
Figure 34: Start Emptying Panel.....	60
Figure 35: Emptying Water-Performing Panel.....	61
Figure 36: Adjustable Alarm Limits	62
Figure 37: Low Core Temperature Alarm.....	70
Figure 38: Temperature Regulation Paused – Core Readout Too Low Message	71
Figure 39: Thermoregulation is Continuing Message.....	71
Figure 40: Low Core Temperature Alarm.....	72
Figure 41: Core Readout too Low Message	72
Figure 42: Thermoregulation is Continuing Message.....	73
Figure 43: Selecting Thermal Disinfection Service.....	85
Figure 44: Initiating Thermal Disinfection.....	85
Figure 45: Thermal Disinfection Mode	86
Figure 46: Selecting System Check.....	87
Figure 47: System Check in Progress.....	87
Figure 48: CliniLogger™ Initialization	99
Figure 49: CliniLogger™ Installation.....	99
Figure 50: Start Installation.....	100
Figure 51: Installation in Progress	100
Figure 52: Installation Complete	101
Figure 53: CliniLogger™ Application Window	102
Figure 54: CliniLogger™ Window	103
Figure 55: Choose CliniLogger™ File Window	103
Figure 56: Complete Message.....	104
Figure 57: CliniLogger™ Viewing Panel	105
Figure 58: Graphic Display Area.....	106
Figure 59: Example: Functional Status Area.....	107
Figure 60: Example: Modes and Errors Area.....	107
Figure 61: Example of Modes and Error Area.....	110
Figure 62: Section of Excel Table	112
Figure 63: Section of Graphic Chart	113

List Of Tables

Table 1: Labels and Symbols	12
Table 2: CureWrap®.....	19
Table 3: Part Numbers for Disposable Temperature Probes and Associated Cables.....	22
Table 4: CritiCool® MINI Screen Keys.....	30
Table 5: Clinical Messages.....	64
Table 6: Technical Messages and Alarms	66
Table 7: Informative Messages.....	68
Table 8: Wrap Ordering Information	74
Table 9: CritiCool® MINI Accessory Kit with Reusable Probes	75
Table 10: CritiCool® MINI Accessory Kit for Disposable Probes.....	75
Table 11: Accessories	76
Table 12: Recommended Routine Inspection and Maintenance Schedule	78
Table 13: CritiCool MINI System Malfunction (No Message) Troubleshooting Guide.....	90
Table 14: Water Tank Overfilling	91
Table 15: CritiCool MINI System Message Troubleshooting Guide.....	92
Table 16: Zoom Tool Buttons	108
Table 17: CliniLogger Mode Codes	111
Table 18: Guidance and Manufacturer's Declaration—Emissions.....	114
Table 19: Guidance and Manufacturer's Declaration—Immunity	115

Chapter 1: Safety Precautions

Definitions

WARNING! *Indicates a condition that may endanger the patient or the system operator.*

CAUTION! *Indicates a condition that may damage the equipment.*

NOTE: *Indicates ways in which the system's operation can be made more efficient.*

Intended Use

CritiCool® MINI is a thermal regulating system, indicated for monitoring and controlling patient temperature.

Warnings

1. The physician must be notified if the patient's temperature does not respond properly, does not reach the prescribed temperature, or if there is any change in the prescribed temperature range. Failure to inform the clinician may result in injury to the patient.
2. The misuse of the temperature regulation equipment can be potentially harmful to the patient.
3. Do not plug wet probes into the sockets of the CritiCool® MINI device.
4. The user should verify that no fluids are present at the skin/wrap interface during the procedure. Failure to do so can cause lesions on the patient's skin.
5. Following use, a pattern resembling the wrap may appear for a short period of time on the patient's skin.
6. Pressure sores may appear or develop when soft tissue is compressed between a bony prominence and external surface. The use of the CritiCool® MINI system does not prevent this from happening.
7. Routine care should be taken during long thermoregulation procedures to prevent pressure sores.
8. Do not lift or move the patient by means of the wrap. This may cause tearing and water leakage.
9. Ensure caution when placing EEG electrodes to avoid puncturing the wraps.
10. Prevent any thermal isolation, such as a pillow or other items, between the wrap and the patient's body.

11. Do not apply heating/cooling to lower extremities during aortic cross clamping. Thermal injury may occur if heating/cooling is applied to ischemic limbs.
12. Wraps cannot be placed over transdermal patches.
13. Wraps should not come in contact with open wounds.
14. Do not touch the ribbon cable behind the display and the patient simultaneously.

Precautions

15. Follow the warning notes listed in the various sections of this manual.
16. Only trained personnel familiar with all system operating procedures and certified only by Belmont Medical Technologies or authorized agents of Belmont Medical Technologies are allowed to use the CritiCool® MINI system.
17. If moisture or leaks are discovered in the connecting hose and/or wrap, turn off the CritiCool® MINI device, disconnect the power cable from its power source, and correct the problem before proceeding.
18. If the device sounds an alarm and/or presents a display other than the standard Belmont Medical Technologies display, the operator should proceed according to the display message and/or the troubleshooting instructions (see [Chapter 7: Troubleshooting](#)).
19. Avoid folds in the wrap—these may obstruct water flow.
20. Do not block the CritiCool® MINI device ventilation grilles. Air must be able to flow freely in and out to keep the device cool.
21. Use sterile or 0.22 µm filtered water. Do not use de-ionized water or water created through reverse osmosis because it may promote corrosion of the metal components of the system.
22. When x-ray imaging is performed on a patient wearing a wrap, shadows from the wrap may appear on the x-ray film.
23. Avoid inserting any sharp object between the patient and the wrap.
24. Read all manufacturers' instructions associated with the temperature probes or temperature probe adapters supplied by Belmont Medical Technologies.

EMC Safety

For safe use of the CritiCool® MINI, it is required to keep CritiCool® MINI at a safe distance from devices emitting radio frequency (RF).

Refer to Appendix B for recommended separation distances between the CritiCool® MINI and the RF source.

Improper Use

Improper use of the CritiCool® MINI system can lead to skin lesions, electrical hazards, and severe changes in body temperature.

Labels













CritiCool® MINI Device Labels















Figure 1: Label Placement For The CritiCool® MINI Device

Label Symbols

Table 1: Labels and Symbols

Description	Symbol
CE Mark of conformity indicates that the product has received the European approval for MDD 93/42/EEC.	
AC Voltage	
Fuse	
The serial number for this product	
Catalogue part number	
European authorized representative	
Switzerland authorized representative	
Caution – refer to user manual	
Type BF equipment	
Recycle for WEEE	
Date of manufacture	
Name of manufacturer	

Description	Symbol
Country of manufacturer	
Do not push	
Refer to instruction manual / booklet	
Restricts the sale and use of this instrument to qualified medical personnel only.	
Unique device identifier	
Instructions for use	
Does not contain natural rubber latex	
Medical device	
Do not reuse	
Not safe in MRI	
Use Sterile Or 0.22 μ filtered water only. Tap water usage is not permitted.	
Electronic Instructions for Use (e-IFU)	

Chapter 2: System Description

CritiCool® MINI is a thermal regulating system, indicated for monitoring and controlling patient temperature.

CritiCool® MINI is based on the CritiCool® system and offers additional benefits with its reduced footprint and mobility.

The CritiCool® MINI system controls targeted temperature management (TTM) in an effective and precise manner. The desired temperature is preset by the physician with a possible range of target temperatures from hypothermia to normothermia.

The system is composed of two elements, the CritiCool® MINI device, and the wrap. The CritiCool® MINI device functions as a control unit and a cooling/heating pump, which circulates water. The control unit monitors the patient's core temperature through specific probes, and using its on-board body temperature control algorithm, delivers water to reach the desired set point temperature. The cooling/heating pump brings the water to the required temperature and the pump circulates it through the specially designed CureWrap®.

The CureWrap® is a flexible 3D single piece design through which the water circulates. It is designed to be in close contact with a large area of the body, thus allowing optimization of energy transfer.

WARNING! *The Belmont Medical Technologies wrap is proprietary to Belmont Medical Technologies and this is the only wrap authorized to be used with the CritiCool® MINI system. Use of any other wrap with the system may harm the patient.*

CritiCool® MINI System

The CritiCool® MINI System Consists Of The Following Elements:

- CritiCool® MINI Device
- CureWrap®
- Accessories

CritiCool® MINI Device

The CritiCool® MINI device has a microprocessor that controls the water temperature flowing into the wrap worn by the patient. The water temperature is controlled and maintained to the desired set point by measuring the actual patient temperature (core and surface) and adjusting the temperature of the wrap accordingly.

Water flow in the wrap is regulated by timed pauses of the flow during clinical operation.

In TTM and normothermia modes, during the initial phase of regulation, the flow cycle is 12 minutes on and 1 minute off. In control rewarming mode, the flow cycle is 12 minutes on and 1 minute off.

In steady state (when the core temp is within the set point range), the cycle is 12 minutes on and 12 minutes off.

CritiCool® MINI Battery

CritiCool® MINI is equipped with a rechargeable lithium-ion battery which allows the system to work without an external power supply for up to 60 minutes. The battery is shipped with a 30% charge and will need to be fully charged before the first use.

Power Cable Connection

Connect The Power Cable To A Hospital-Grade Power Outlet.

Grounding The System

To protect the patient and hospital personnel, the CritiCool® MINI system must be grounded. Accordingly, the system is equipped with a detachable 3-wire cable which grounds the instrument to the power line ground (protective earth) when plugged into an appropriate 3-prong receptacle.

WARNING! Do not use a 3-to-2-wire adapter with this instrument.

Warnings

Charging should be performed in a fire-safe area, away from flammable surroundings.

Charging should be performed in an environment temperature of between 4°C and 30°C (39.2°F - 86°F).

Use only the Belmont Medical Technologies original power cord supplied with the ground plug.

External Features

Front View

Key – CritiCool MINI Front View:

- | | |
|-------------------------|--|
| 1. Display touch screen | 8. Surface sensor socket |
| 2. Functional buttons | 9. Core out temperature |
| 3. On/off button | 10. Water-in quick coupling connector |
| 4. Battery indicator | 11. Water-out quick coupling connector |
| 5. AC indicator | 12. Water level indicator |
| 6. Speaker | 13. Water tank cap |
| 7. Core sensor socket | |



Figure 2: Front View

Rear View

Key – CritiCool MINI Rear View:

- | | |
|----------------------|-------------------------|
| 1. Air Outlet Grille | 4. Air Inlet Grille |
| 2. Rear Side Cover | 5. AC Power Plug |
| 3. Fan | 6. RS-232 Communication |

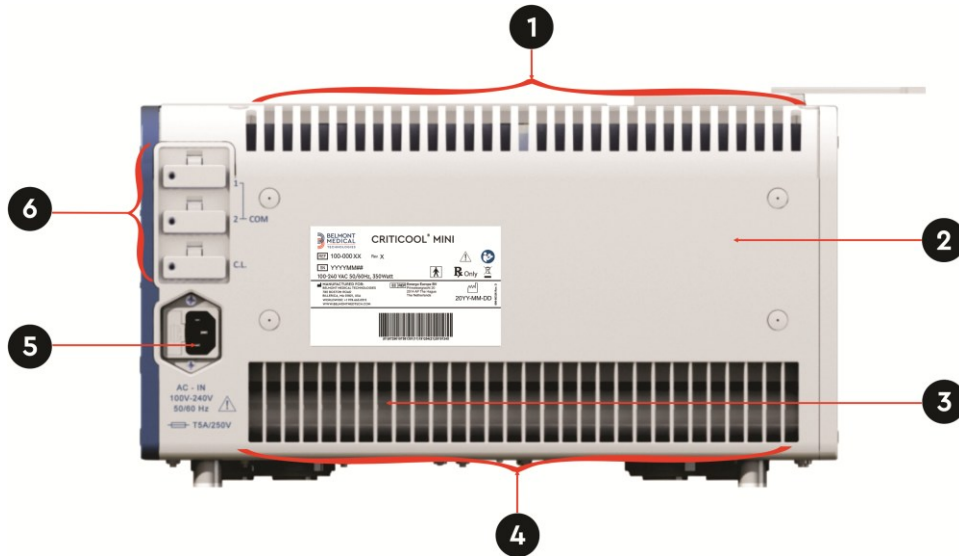

Figure 3: Rear View

Garment/Wrap

General

The wrap is a one-piece covering with inflow and outflow tubes that circulate water in the wrap channels. It is designed to facilitate the wrapping of individual parts of the body (chest, arms, thighs, etc.) To maximize surface coverage.

Description and Intended Use

The Wrap Is:

- Disposable
- Biocompatible
- Latex Free
- Antistatic
- Adjustable

Each section of the wrap is separately wrapped around the appropriate area of the patient to ensure maximum body surface coverage. The wrap is intended to fit loosely. Review the CureWrap instructions for use leaflet supplied with the wrap for further information.

The water's exit and entrance points are short sections of tubing integrated with a quick coupling connector (QCC) and welded to convenient locations on the edges of the wrap.

The wrap design allows the physician to cover a maximum surface area as needed.

WARNING! *The wraps are designed for single patient use only. Reusing may cause cross contamination and/or irritation.*

Wrap material

- Patient side: non-woven polypropylene
- Exterior: brushed loop fabric

Usage duration

- The wrap is durable for up to 5 days. Replace the wrap if it becomes soiled.

Selected Wrap Design

The wraps are available in a range of sizes and are selected based on patient size.

Table 2: CureWrap®

CureWrap®	Part Number	Patient Weight	Wrap Length/ Width (M)
CureWrap® Infant	508-03518	2.5-4.0 Kg	0.659 / 0.448
CureWrap® Infant	508-03521	4.0-7.0 Kg	0.698 / 0.602
CureWrap® Infant Assorted	PED-SM008	2.5-4.0 Kg (X4) & 4.0-7.0 Kg (X4)	0.659 / 0.448 0.698 / 0.602

Accessories

The following accessories are available for use in conjunction with the CritiCool® MINI system.

Temperature Probes

Intended Use

Core temperature probes are used to measure the patient's core temperature.

Surface temperature probes are used to measure the patient's surface temperature, in a location not covered by the wrap.

NOTE: *Reusable temperature probes are not available for sale in the USA and select markets.*

Reusable Temperature Probes

There are three color-coded temperature probes: core (gray), surface (green), and infant core (gray). Both core and surface temperature probes must be plugged into the CritiCool® MINI device. The core temperature probe must be inserted, and the surface temperature probe must be attached to the patient for the device to function properly.

CAUTION! *The cleaning, disinfection and the sterilization of the reusable temperature probes are done in accordance with the manufacturer's directions. Refer to the manufacturer's user guide for details.*

Core Temperature Probe

The core temperature probe (gray) measures core body temperature when inserted into the patient's body. The plug of the probe cable is inserted into the gray core socket at the front of the CritiCool® MINI device.

Infant Core Temperature Probe

The infant core temperature probe (gray) measures infant core body temperature when inserted into the patient's body. The plug of the probe cable is inserted into the gray core socket at the front of the CritiCool® MINI device.

Surface Temperature Probe

The surface temperature probe (green) measures body surface temperature when attached to the patient's skin. The plug of the probe cable is inserted into the green surface socket at the front of the CritiCool® MINI device.

Note: *The response time for temperature feedback to the CritiCool MINI for all temperature probes once plugged in and attached to the patient is less than 60 seconds.*

Disposable Temperature Probes

Disposable temperature probes are attached to two color-coded adapters: gray (core) and green (surface). Both adapters are reusable. For the device to function properly, the core temperature probe must be inserted into the patient and the surface temperature probe must be attached to the patient's skin.

CAUTION! *Before use, please check the packaging and expiration date of the disposable temperature probes. If the package seal is not intact or the probes have expired, do not use. Review the instructions for use and contraindications for the probes prior to use.*

Disposable Surface Temperature Probe:

The disposable surface temperature probe is attached to the reusable surface adapter (green). The adapter is plugged into the green surface socket at the front of the CritiCool® MINI device. The temperature probe is attached to the patient's skin and measures surface body temperature.

Disposable Core Temperature Probe

The disposable core temperature probe is attached to the reusable core adapter (gray). The adapter is plugged into the gray core socket at the front of the CritiCool® MINI device. The temperature probe is inserted into the patient and measures core body temperature.



Adapter Cable	Disposable Temperature Probe
Surface	
	
PN# 014-00324	PN# 014-00323
Core	
	
PN# 014-00028	PN# 014-00035 / 014-00036

Figure 4: Disposable Temperature Probes Connection

Table 3: Part Numbers for Disposable Temperature Probes and Associated Cables

Part Number	Description
Surface	
014-00324	Adaptor Cable For Disposable Surface Temperature Probes, 3.5 mm (1/8") Mono Socket, Green
014-00323	Disposable Surface Temperature Probe, 3.5 mm (1/8") Mono Jack (50/Pack)
Core	
014-00028	Adaptor Cable For Disposable Core Temperature Probes, Molex, Gray
014-00035	Disposable Core Temperature Probe, 9 Fr, Smiths Medical ER400-9 (20/Pack)
014-00036	Disposable Core Temperature Probe, 7 Fr, Metko FMT400/AOR-D2 (40/Pack)

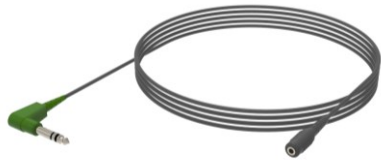
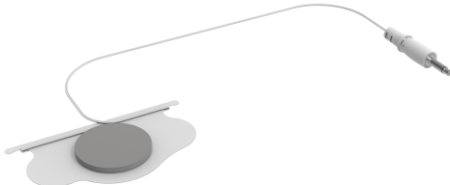
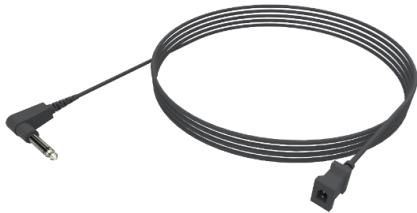
Detachable Electric Power Cable & Plug

Use the power cord to power the device and charge the battery.

Connecting Tubes For Wraps

Two flexible 2.5 m long, reusable connecting tubes connect the wrap with the CritiCool® MINI device to enable the flow of water between them.

The tubes are supplied as a paired unit with two male quick coupling connectors for the CritiCool® MINI device and with two female quick coupling connectors for the wrap.

Male Connector For Draining Water Tank

The male connector is used to drain the water tank. It connects to the outflow hose of the quick coupling connector of the connecting tubes.

Spare Water Filter

The spare water filter is used for annual filter replacement.

System Specifications

See the following page for system specifications.

CritiCool® MINI Technical Specifications

CritiCool® MINI, one of Belmont Medical Technologies' temperature regulating systems, induces, maintains and reverses hypothermia in an effective and precise manner. The desired patient temperature is preset by the physician with a possible range of target temperature from mild hypothermia to normothermia.

The system is composed of two elements, the CritiCool MINI device and the CureWrap® garment. The CritiCool® MINI device functions as a control unit, constantly monitoring the patient's core temperature every 133 milliseconds, and as a cooling/heating device which brings the circulating water to the required temperature by using its on-board body temperature control algorithm. CritiCool® MINI is designed for either bedside use, or as a device for thermoregulation treatment with battery backup during in-hospital transport. The CureWrap® is a flexible 3D single-piece garment through which water circulates. It is designed to be in close contact with a large area of the body to optimize energy transfer.

Control Unit

Physical Dimensions	384 Mm W X 323 Mm D X 216 Mm H (15.11" W X 12.71" D X 8.5" H)
Net Weight	11 Kg / 24 Lb
Environmental Operating Conditions	
Temperature	5°C To 40°C (41-104°F)
Humidity	10 To 93%, Non-Condensing
Note:	Not intended to be used in an oxygen rich environment. Do not use in an atmosphere with flammable anesthetic mixtures.
Environmental Storage Conditions	
Ambient Temperature	-15°C To +45°C (5-113°F)
Humidity	10 To 93%, Non-Condensing
Service Life	7 years
Hardware	
Electricity Input Power	100-240 VAC 50/60 Hz
Maximum Power Consumption	350 Watts
Battery Power	Lithium Ion 14.8V / 10.4 A
Work Time On Battery	Up To 1 Hour
Battery Charge Time	6 Hours (Internal Charger)

Battery Cycle Life	Approximately 70% Capacity After 500 Cycles
Heat Exchangers	Peltier Technology - Thermoelectric Coolers (Tecs)
External Ports	3 X Isolated Serial Port
LCD Display Size	144.8mm / 5.7" Color Display
LCD Display Resolution	320x240
User Interface	Multi-touch capacitive display screen 5 soft push buttons
System Sensors	2 Internal Temperature Sensors: Water In/Water Out 2 Pressure Sensors
Safety Measures	Over pressure protection and alarm High water temperature protection and alarm
Water	
Water Type:	Sterile Or 0.22 Micron Filtered Water
Tank Capacity:	1.2 Liters (0.317 Gallon)
Pump Rate:	1.2 L/Minute
Water Temperature Accuracy:	±0.3°C (0.54°F)
Water Temperature (Outflow) Range:	13-40.8°C (55.4-105.4°F)
Patient Temperature	
Patient Temperature Channels	2 Channels: 1) Core and 2) Surface
Patient Temperature Sensor Accuracy	±0.3°C (0.54°F)
Core Out Temperatures	
Interface	Phone jack
Isolation	3 KV
Core Out Temperature Sensor Accuracy	±0.2°C (0.36°F)
Core Out Temperature Sensor Range	16-45°C (61-113°F)
Software	
Modes Of Operation (Continuous)	Targeted temperature management (TTM) Controlled rewarming Normothermia Stand by (no thermo regulation; monitoring only)

Patient Set Point Temperature	
Controlled Rewarming Default Target	36.5°C
Controlled Rewarming Default Rate	0.05°C – 0.5°C Per Hour
Manual Rewarming Rate	Adjustable In 0.1°C Increments
Adjustable Alarm Limits	High Patient Temperature Low Patient Temperature High Water Temperature
Displayed Information	Mode Of Operation Care Time System Status and Alarms Patient Set Point Temperature Patient Target Temperature Patient Core Temperature Patient Surface Temperature Temperature Graph Technician Mode and Display Water Temperature on graph
Languages	
<ul style="list-style-type: none"> • English • Czech • Danish • Dutch • Finnish 	<ul style="list-style-type: none"> • French • German • Italian • Norwegian • Polish
<ul style="list-style-type: none"> • Portuguese • Russian • Spanish • Swedish • Turkish 	
CureWrap®	
Range Of Sizes	44 cm – 60 cm
Duration Of Use	Up to 5 days unless soiled
Wrap Storage	
Shelf Life	5 Years
Temperature Conditions	10°C To 27°C
Humidity Conditions	10-90%
Wrap Transport	
Temperature Conditions	-20°C To 60°C
Humidity Conditions	20-95%

CliniLogger™

CliniLogger™ is an optional accessory for CritiCool® MINI thermoregulation systems and is used to collect the system parameters during the thermoregulation procedure.

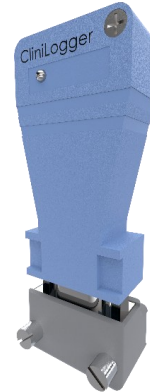

Hardware

Connector	DB9 connector for serial interfacing to CritiCool® MINI Or General PC
Size	35 X 65 Mm
Controller	MSP4301611 Micro controller with the following features: <ul style="list-style-type: none"> – Built In Flash and RAM – Built In UART & SPI – Built In DMA Controller
Memory	Flash Memory Capacity: 2 MB
Power Requirement	5 Volt DC Supplied From The CritiCool® MINI Or General PC <ul style="list-style-type: none"> – <20 Ma – <100 Mw
LED	Bicolor (Green / Red)
Data Storage Rate	Every 1 Minute Into Flash Memory
Serial Communication	RS232: <ul style="list-style-type: none"> – 19200 Bps To CritiCool® MINI – 115200 Bps To PC
Data Collected	Temperature: Set Point, Core, Surface Time Water Circulation ON/OFF Water Heat/Cool Mode Of Operation Errors
CliniViewer Software	PC Application

Chapter 3: Installation

Pre-Installation Requirements

Space and Environmental Requirements

The CritiCool® MINI device must be located no less than 5 cm (2") from other objects to avoid the impairing of ventilation to the CritiCool® MINI device.

The following dimensions of CritiCool® MINI should be considered when placing the device:

384 mm w x 323 mm d x 212 mm h / (15.11"w x 12.71"d x 8.5"h)

Electrical Requirements

100-240V 50/60 Hz

WARNING! *To avoid the risk of electric shock, this equipment must only be connected to a mains supply with protective earth. (PE).*

Equipment List

The CritiCool® MINI system includes the following:

- CritiCool® MINI Control Unit
- Power Cord
- Spare Filter
- User Manual
- Quick Reference Guide
- Accessory Kit For CritiCool® MINI – one of the following:
 - 200-00200 accessory kit with reusable temperature probes
 - 200-00201 accessory kit for disposable temperature probes

Unpacking and Inspection

The unit has undergone full quality assurance testing before shipment and should be operational upon delivery.

NOTE: Report any container damage prior to opening the container, or any unit damage prior to unpacking, installation, or testing to your Belmont Medical Technologies authorized representative or distributor.

Unpacking CritiCool® MINI From The Box

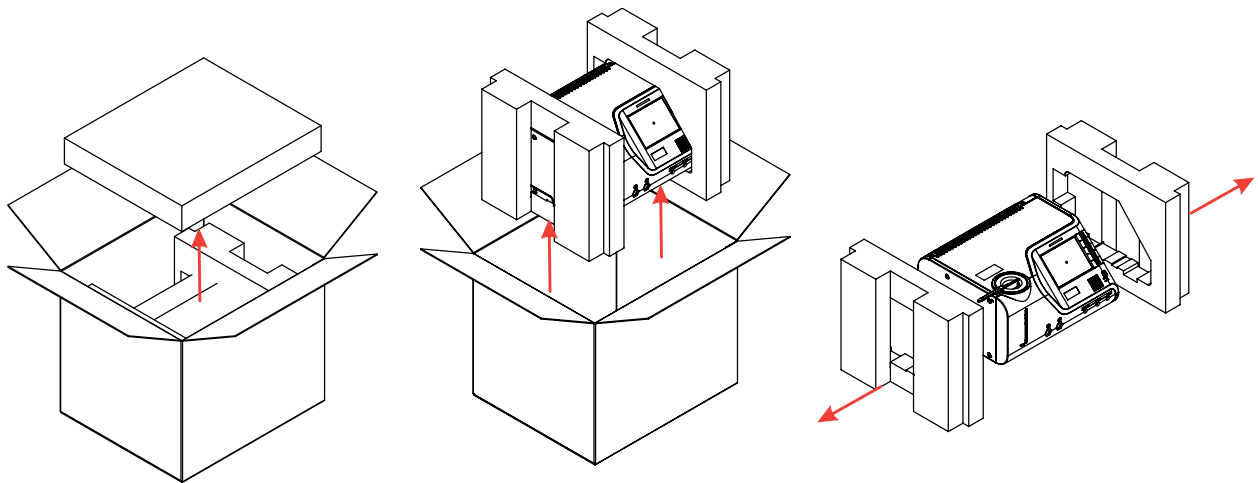

Moving The Unit – Preparation

Before moving the unit:

1. Ensure that the CritiCool® MINI device is off by pressing the ON / OFF switch.
2. Ensure that all electrical connections are disconnected.
3. Ensure the water tank cap is on.

Chapter 4: Operating Instructions

CritiCool® MINI Functions

CritiCool® MINI is used for patient thermoregulation.

NOTE: *The system starts up in one of the two functions, according to the settings (see [Figure 26: Settings Screen 1](#)).*

Patient thermoregulation includes the following modes:

- TTM: Targeted Temperature Management
- Controlled rewarming: slow rewarming
- Normothermia
- Empty: this mode appears only at startup. Otherwise, it is found in the services menu.

Controls, Functions, Indicators and Connections





Main Power Switch

The main power switch, located at the front of the unit, switches the CritiCool® MINI device ON and OFF. The self-test panel is displayed (see [Figure 5: Self Test Screen](#)). At the end of the self-test an alarm is automatically activated.

CritiCool® MINI Screen Controls

The CritiCool® MINI screen is a touch screen, with additional hard keys to the right of the panel:

Table 4: CritiCool® MINI Screen Keys

Icon	Description
	Main Menu and Escape
	Show Graph / Change Graph Parameters
	Alarm Tone ON/OFF
	Open Setting Panel / Change Setting
	Accept Change

NOTE: *The alarm icon is an informative icon only. To silence an alarm, the user must press the hard key of the alarm, located to the right of the panel.*

QCC— Quick Coupling Connector

The quick coupling connectors are located at the front of the CritiCool® MINI device (see circle below) and are connected to the wrap by the connecting tubes.



Quick Coupling Connectors

To Connect The Connecting Tubes:

1. Lock the connecting tubes by pressing the metal ends of the tubes into each metal connector on the device (see below); when locked, a clicking sound is produced.



2. Verify that the tubes have been locked by lightly tugging them towards you.

To Disconnect The Connecting Tubes:

3. Press the metal flange and pull out the connecting tubes.

Temperature Probe Sockets

There Are three temperature probe sockets located at the front of the CritiCool® MINI device:

4. Core – for the core temperature probe
5. Surface – for the surface temperature probe
6. Core out – for the core out (temperature out) cable

Patient Thermoregulation – Step by Step Operation

Preparing the System for Operation

To prepare the system for operation:

1. Place the unit in the desired position according to “Space and Environmental Requirements”.
2. Remove the water tank feeder cover and pour in only sterile water until the maximum allowable level is reached (minimum water temperature 13°C / 55.4°F).
3. Observe the water-level indicator to prevent overfilling the water tank. Close the water tank feeder cover.
4. Connect CritiCool® MINI to the power source.

NOTE: Use only sterile water or 0.22 micron filtered tap water.

NOTE: In case of overfilling, see [Table 6: Technical Messages and Alarms](#).

Operating the System

To turn on the system:

1. Hold down the main power switch at the lower right front of the unit. (See Figure 2: Front View). The Self-Test panel is displayed. At the end of the Self-Test, the alarm is automatically activated.



Figure 5: Self-Test Screen

2. If the Self-Test discovers a condition that may impact operation, a Halt Error will occur. Halt 4 is shown below as an example.



Figure 6: Halt Error

- In this case, turn off the system, wait at least ten minutes, and then power on the system. If the halt error reappears upon startup, the system should be evaluated by a Belmont trained biomedical technician, and the name of the error provided (“Halt 4”, in the above example).
- The Service Manual includes more troubleshooting information for Halt errors.

3. Following a successful Self-Test, the system automatically starts to cool the water through internal circulation (as in Standby Mode) (See [Figure 11: Standby](#)).
4. Select the appropriate wrap, take it out of the package and place it on the bed or underneath the patient. (See [Table 2: CureWrap®](#)).

CAUTION! *Power interrupt*

The CritiCool® MINI has a battery backup that, if charged, will continue operation for up to an hour if not connected to direct power. If power does not return within this period, the system will shut down.

The return of power after shutdown will activate the system to default settings, irrespective of the mode prior to shut down.

NOTE: *When using CritiCool MINI in TTM mode, it is highly recommended to let the CritiCool® MINI run before connecting temperature probes and hoses to allow the water to cool.*

NOTE: *Do not wrap the patient at this time. The Wrap should not be fastened around the patient until it has filled with water.*

Inserting and Attaching Temperature Probes

WARNING! For proper use of the CritiCool® MINI device, the core temperature probe must be inserted, and the surface temperature probe must be attached to the patient per the probes instructions for use. The location of the surface temperature probe is a clinical decision. All temperature probes directly measure temperature.

1. Insert the core temperature probe or gray adaptor cable (reusable or disposable) into the left socket labeled “CORE” color-coded with gray on the front of the device. (See [Figure 2: Front View](#)).
2. Insert the core temperature probe (reusable or disposable) into the patient’s rectum or esophagus.
3. Insert the surface temperature probe or green adaptor cable (reusable or disposable) into the right socket labeled “SURFACE” color-coded with green on the front of the device.
4. Attach the surface temperature probe (reusable or disposable) to an exposed area of skin with adhesive tape. When the patient is wrapped, the surface temperature probe should not be under the CureWrap or covered.

NOTES:

- The CritiCool® MINI device does not initiate thermoregulation if the Core temperature probe is not properly positioned into the patient. Ensure that direct patient feedback is monitored at all times.
- The disposable temperature probes need to be connected to an adapter. Make sure to connect the appropriate probe to its adapter (note the labeling on the adapter).
- Be sure to read and follow the instructions for use noted on the temperature probe being used, paying particular attention to indications and contraindications.

Connecting the Water Hoses (Tubes) to CritiCool MINI

The Quick Coupling Connectors (QCC) are located at the front of the CritiCool® MINI device.

To connect the water tubes to CritiCool® MINI:

1. Before connecting the water tubes, press the metal flange on each QCC to ensure 'open position' of the connector.
2. Lock the connecting tubes by pressing them against the connectors. When locked, a clicking sound is produced.
3. Verify that the tubes are locked by lightly tugging them towards you.
4. Connect water tubes to wrap and to CritiCool® MINI. Open the clamps on the wrap, if necessary, and the wrap will automatically fill.
5. Now that the wrap has filled, secure the wrap to the patient. Refer to the Instructions for Use of the wrap leaflet supplied with each wrap.

NOTE: *If the tubes are not properly connected to the device, or the clamps to the wrap are closed, water will not flow to the wrap, and you will notice the disappearance of the OK symbol in the top left corner.*

To disconnect the tubes:

- Press the metal flange and pull out the connecting tubes.

NOTE: *Water may drip from the inlet tubes of the wraps. Be sure that no electrical device or outlet is located under the CritiCool® MINI's water inlet or wrap tubes.*

Activating the System

After the self-test, the Select Mode screen appears with Targeted Temperature Management (TTM) mode highlighted.



Figure 7: Select Mode Upon Startup

NOTE: *In Software Version 2.1 & 2.2, the system will always display the Mode Select screen after the self-test, each time the device is powered on—regardless of the previous shutdown sequence.*

Touch the required mode, then touch **OK**.

The Thermoregulation Main Screen Control Panel appears.

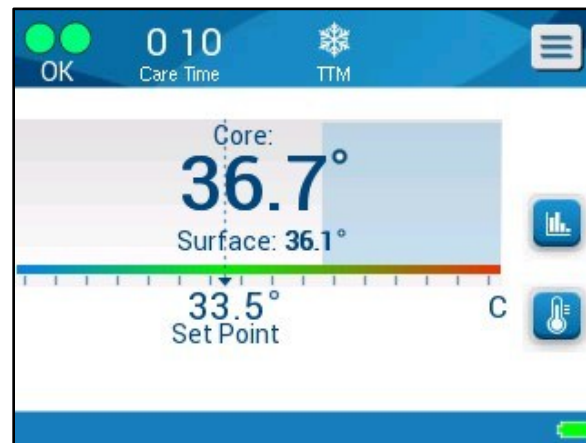

Figure 8: Main Screen

Once CritiCool® MINI is turned on, all operating functions are controlled by the LCD Touch Screen. Alternatively, the control panel's hard keys and visual displays guide you through each operational phase as well.

Wrapping the Patient

After the desired mode has been chosen and water has filled the wrap, the CureWrap can be positioned around the patient. Follow the CureWrap Instructions for Use pamphlet when wrapping the patient, being careful to keep a finger's breadth between the patient and the wrap.

NOTE: Before securing the wrap to the patient with the Velcro strips, confirm that the wrap has filled with water.

Control Panel

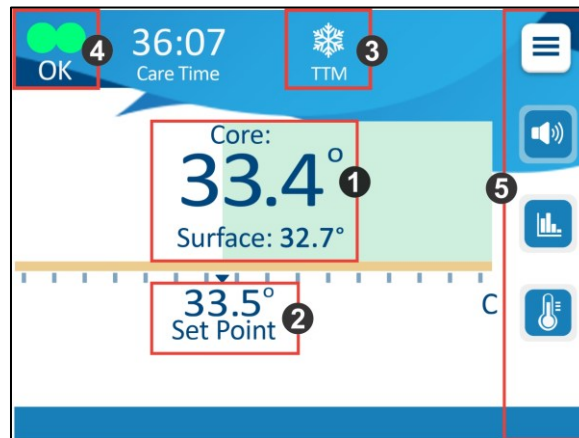







Figure 9: Control Panel

The Control panel displays the following:

- Patient Core and Surface temperatures ①
- Set Point temperature ②
- CritiCool® MINI Mode ③
- OK indicator to indicate that the system is functioning correctly ④
- Action icons and touch keys ⑤

- Menu  / Escape 
- Alarm ON / OFF 

NOTE: The alarm icon appears only if there is an alarm condition. This icon is informative only and not an action button. (It is not a touch button).

- Graphical Display of CritiCool® MINI Parameters 
- Set Point / Target Temperature Control 

The Main Menu

Touch the Menu icon .

A list of options opens:

The options include the following:

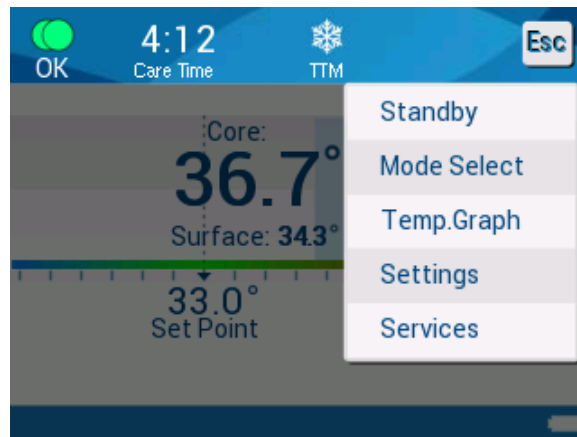

Figure 10: Main Menu

- Standby
- Mode Select
- Temp Graph
- Settings
- Services

Standby Mode

In this mode, there is no water circulation to the wrap and no thermoregulation. The CritiCool® MINI Device keeps monitoring patient temperatures, circulating the water internally and maintaining the water temperature for when returning to TTM or Normothermia modes.

During Standby mode, a message displays showing only the patient's temperature.

NOTE: *During Standby Mode, there is no temperature regulation. Use this mode when replacing the wrap or when the wrap needs to be disconnected temporarily from the machine (e.g. For intra-transport or CT/MRI imaging).*

To go to Standby:

1. Touch the MENU icon .
2. Touch **Standby**.

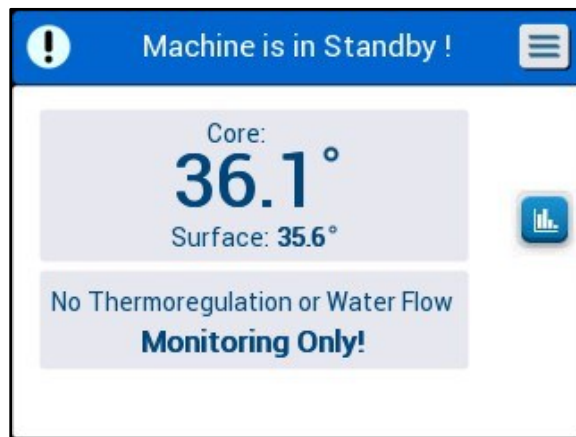

Figure 11: Standby

Mode Select

The MODE SELECT panel enables choosing the mode of operation:

- TTM (Targeted Temperature Management)

Use this mode for Targeted Temperature Management. This mode is useful for any procedure where thermoregulation is required to bring the patient's temperature to a stable set point temperature.

- Controlled Rewarming

This mode provides gradual controlled rewarming. Each step of the procedure increases the set point temperature by a fixed, small step in temperature for a predefined period. The step is always related to the core temperature reached at the end of the previous stage. From the settings screen, you can choose the rewarming rate.

- Normothermia

This mode is for quickly reaching a normal body temperature. This mode should not be used for patients undertaking cooling therapy.

NOTE: *When switching to Normothermia, the system keeps the last set point of the preceding mode.*

To select a mode:

1. Touch the MENU icon .
2. Touch **Mode Select** to display the select mode panel.



Figure 12: Select Mode Panel

3. Touch the required mode icon. The selected mode is now highlighted.
4. Touch **OK** to activate the mode.

NOTE: *The selected mode icon is shown on the top of the main screen (see [Figure 8: Mainscreen](#)).*

NOTE: An alarm sounds if a mode is NOT selected after 5 minutes and repeats every 5 minutes if muted.

TTM (Targeted Temperature Management) Mode

When TTM mode is selected, a default Set Point (SP) temperature appears on the Main Screen. The default temperature is 33.5°C (92.3°F).



Figure 13: TTM Mode

CAUTION! The default setting is intended to maintain TTM. The default set point may be changed by clinician in the settings option.

The TTM Set Point temperature for the patient may be changed by using the Set Point Control icon.

The system provides the physician with the option of selecting a body temperature in the range of 30°C-40°C (86°F-104°F).

CAUTION! The desired set point temperature should only be set by the physician or under the order of a physician.

Once adjusting the set point, the CritiCool® MINI device automatically operates at the optimal level to obtain the desired set-point temperature. The set point temperature should therefore be set at the beginning of the TTM mode and not changed until the patient should be rewarmed or the desired patient temperature changes.

After setting the set point temperature, follow the on-screen instructions and operate as instructed.

NOTE: When there is a difference between the Set-Point Temperature and the Core Temperature, a further decrease in the Set-Point temperature does not affect the water temperature in the wrap.

NOTE: Short transient changes in core temperature do not affect thermoregulation and are compensated for by the system.

NOTE: The rate of temperature change depends on several clinical factors, including the size of the patient, medications being administered, and health indicators.

Controlled Rewarming Mode

This mode is used for slow, gradual rewarming following TTM.

In Controlled Rewarming Mode, CritiCool® MINI increases the set point automatically in small steps until it reaches a normothermic target temperature.

In this mode, the normothermic goal temperature is displayed as **Target Temperature**. The next rewarming step, or Rewarming Virtual Set Point (RVSP), displays as **Next Step**.

NOTE: *All thermoregulated patients should be closely monitored. Adjustments may still be required in Controlled Rewarming Mode.*

NOTE: *If unexpected temperature fluctuations are noted when maintaining patient temperature, either 1) closer monitoring, 2) a slower rewarming rate, 3) and/or manual rewarming is recommended.*

The rewarming step rate is configured in the Settings Screen as shown below. Available rates are offered from 0.05°C to 0.5°C per hour in increments of 0.05°C.

To set the hourly rewarming rate:

1. Touch the MENU icon .
2. Touch **Settings** in the Menu.
3. Insert password and press the **OK** button.



Figure 14: Selecting a Rewarming Step

4. Choose the desired rewarming rate per hour (“Rewarming Step”).

The duration of the rewarming step depends on the rewarming step chosen:

- 30 minutes: rewarming rates of 0.15°C/hour or faster
- 1 hour: 0.10°C/hour rewarming rate
- 2 hours: 0.05°C/hour rewarming rate

NOTE: *Slower rewarming rates are recommended.*

5. Touch **OK** to return to the Main Screen.

NOTE: *If the rewarming rate is changed during rewarming, the user should reinitiate Controlled Rewarming Mode to immediately implement the new rewarming rate by selecting Menu, Mode Select, Controlled Rewarming. In version 2.1 and 2.2, this will result in maintaining core temperature for one rewarming step.*

The selected rewarming step is displayed on the main operating screen as **T/h**.

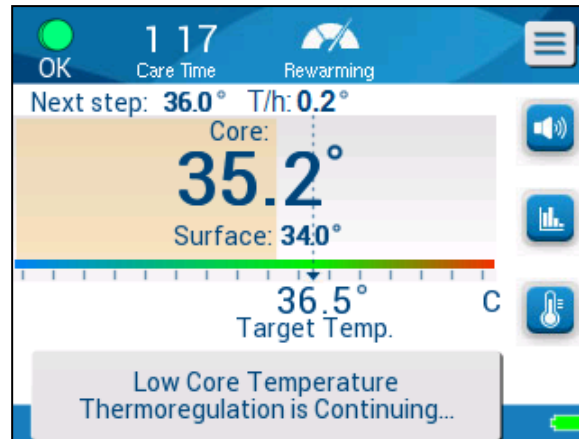

Figure 15: Rewarming Step on the Main Screen

Controlled Rewarming Process

The Controlled Rewarming process starts with the patient at a mild hypothermia temperature.

According to the pre-determined steps of rewarming, the system elevates the patient's temperature, each rewarming step, to a Rewarming Virtual Set Point (RVSP). The RVSP is displayed on the screen in Controlled Rewarming Mode as the "Next Step."

For example:

The patient core temperature is 33.5°C and the selected step temperature elevation is 0.4°C/hour.

The Rewarming Virtual Set Point will be increased by 0.2°C every half hour. $33.5 + 0.2 = 33.7^\circ\text{C}$, therefore the goal over a period of 30 minutes would be 33.7°C.

Assuming that at the end of the 30 minutes period, the core temperature has reached 33.7°C, the Controlled Rewarming algorithm adds 0.2°C to the last virtual set point and the new virtual set point is now $33.7 + 0.2 = 33.9^\circ\text{C}$ for an additional 30 minutes, and so on, until the core temperature reaches the target temperature.

NOTE: *The rewarming rate chosen in Settings is the desired average rewarming rate over the course of the rewarming period. It would not be unusual if a patient warmed more in one period and less in another, as the algorithm compensates based on actual patient temperature, adjusting for multiple factors.*

To Start Controlled Rewarming (or Re-Initiate Controlled Rewarming):

1. Touch MENU icon .
2. Touch mode select to open MODE SELECT panel.

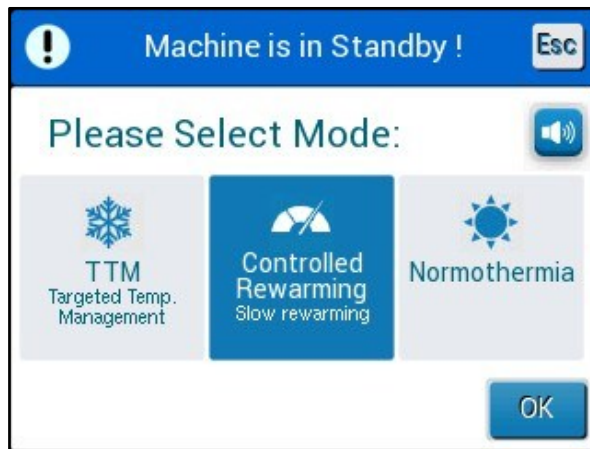

Figure 16: Select Mode - Controlled Rewarming

3. Touch controlled rewarming.
4. Touch **OK**.

The following message appears:



Figure 17: Switching to Rewarming Mode

5. Confirm that the core temperature appears correct by checking the value on the screen, then that the probe is properly positioned, then again check the on-screen value. It may take up to two minutes for the values to stop fluctuating.
6. Once the core temperature appears stable, touch OK to start the rewarming process.

NOTE: *If "OK" is pressed before repositioning the probe or before values stabilize, an inaccurate core temperature may be used to calculate the Rewarming Virtual Set Point (RVSP).*

7. Controlled Rewarming Mode has now begun. CritiCool® MINI continues circulation.
8. Confirm the patient core and skin temperatures shown on the screen appear accurate.
9. Follow the instructions below to change **Target Temperature**.

NOTE: *In the "Controlled Rewarming" mode, the set point display changes to "Target Temperature" with a default of 36.5°C. The "Target" temperature is the temperature at which the Controlled Rewarming process ends.*

NOTE: *After the Controlled Rewarming step is selected, it takes time for the system to reach equilibrium and adjust the patient's temperature according to the programmed rewarming step. This is due to variabilities in individual patient medication, health indicators and the environment.*

If, during the rewarming phase, the core temperature becomes more than 0.8°C below the Target Temperature, the following message appears:

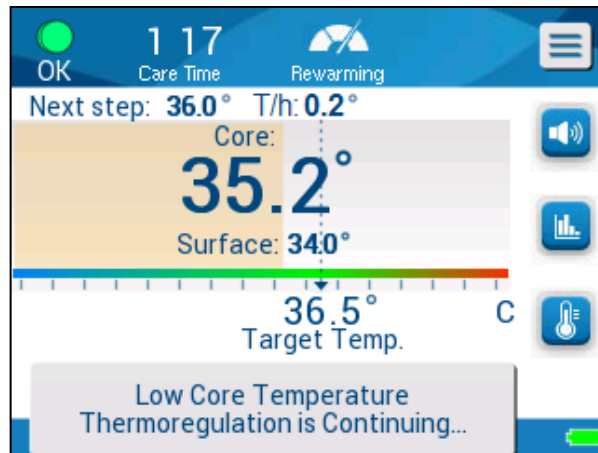

Figure 18: Low Core Temperature

If, during the rewarming phase, the core temperature becomes more than 2°C below the target temperature, the following message appears:

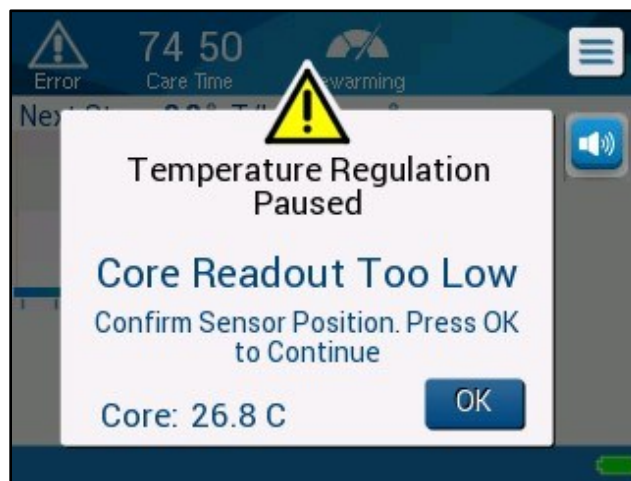

Figure 19: Temperature Regulation Paused Message

“Check that the Core Temperature Probe is positioned correctly in the patient and then touch OK to continue rewarming.”

NOTE: *While this screen is displayed, the machine is not thermoregulating the patient and there is no water flowing to the wrap!*

Target Temperature Setting

In the "Controlled Rewarming" mode, the Set Point display changes to "Target Temp". The target temperature is the temperature at which the controlled rewarming process ends.





Figure 20: Target Temp.

The Target Temperature can be set between 32.0°C (86.0°F) to 38.0°C (104.0°F) with a default of 36.5°C (97.7°F).

NOTE: This panel is accessible only in the Controlled Rewarming Mode.

To change the Target Temperature:

1. Touch the Set Point/Target Temp icon .
2. Use  and  to modify the target temperature.



NOTE: The  and  icons provide a change of 0.1°C. Each scale mark in the toolbar provides a change of 1°C



Figure 21: Target Temperature Setting Panel

Touch **OK** to confirm.

Target Temperature should now be displayed correctly.

The First Step of Controlled Rewarming (Software Version 2.1 and 2.2 only)

The flow icon starts to move, and a message appears “Holding Core Temp for First Step of Rewarming.”



Figure 22: Holding Core Temp for First Step of Rewarming

The message on the screen and core temperature will be maintained for the entirety of the first rewarming step. During this time, the Rewarming Virtual Set Point (RVSP) will be set to the current core temperature.

The duration of the temperature hold depends on the Rewarming Step selection in Settings (See [Figure 14](#)).

After the First Step of Controlled Rewarming (All Versions):

Upon completion of the first rewarming step, the system will reset the RVSP based on current core temperature and then proceed to increase the RVSP until the target temperature is reached. An accurate core temperature reading is vital for proper thermoregulation. Close monitoring is also necessary during thermoregulation, especially when rewarming.

Completing Controlled Rewarming

When core temperature reaches the target temperature, a message will appear “Target Temperature Has Been Reached.” (Software Version 2.1 and 2.2 only.) The message will remain for 60 minutes. See image below.



Figure 23: Target Temperature Has Been Reached

No message appears for software versions 2.0 and earlier.

CritiCool® MINI continues to maintain the body temperature according to the target temperature.

- If thermoregulation with CritiCool® MINI is complete, refer to the instructions on preparing CritiCool® MINI for storage (Chapter 6, section *Before Storage*).
1. If continued thermoregulation is desired, Normothermia Mode should be used.
 2. Choose Menu, Mode Select, then Normothermia Mode.
 3. Adjust the Set Point temperature as needed.

Troubleshooting in Controlled Rewarming Mode

Repositioning/Confirming Positioning of Core Probe

If rewarming seems unusual, first confirm that the core temperature probe is properly inserted and secure and that the reading is accurate and stable. It may take up to two minutes for the reading to stabilize.

When monitoring the patient or anytime the core probe dislodges from the patient, check the core probe, then consult the CritiCool® MINI screen and compare **Core** temperature against **Next Step**.

NOTE: *In the main screen, the "Next Step" (Rewarming Virtual Set Point) indicates the direction of core temperature in the immediate future. For most rewarming rates, it represents the goal core temperature for the next 30 minutes.*

Initiating/Reinitiating Controlled Rewarming Mode

If Next Step does not look correct, reinitiate Controlled Rewarming Mode by selecting Menu, Mode Select, Controlled Rewarming and reconfirming core temperature when the “Switching to Rewarming” message appears. This will recalculate the RVSP. In version 2.1 & 2.2, it will also result in holding the core temperature for the next step of rewarming.

“Core Readout Too Low” in Controlled Rewarming Mode

If, during the Controlled Rewarming phase, the core temperature becomes more than 2 degrees below the target temperature, or if rewarming is going significantly more slowly than expected, the following message appears:

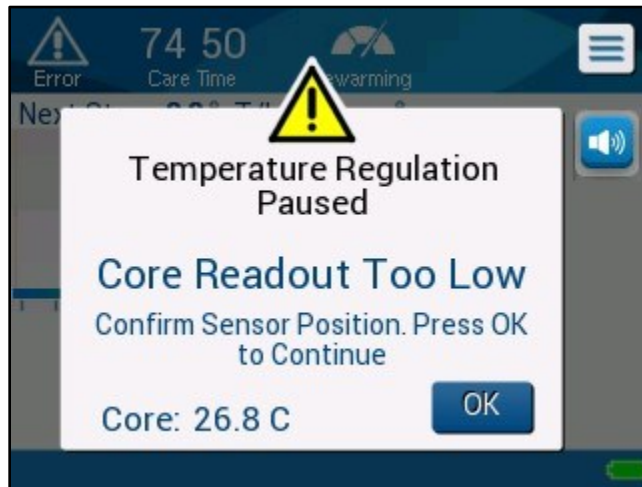

Figure 24: Temperature Regulation Paused Message

NOTE: While this screen is displayed, the machine is not thermoregulating the patient. Alarms should be promptly addressed.

NOTE: If this message flashes repeatedly, reinitiate Controlled Rewarming Mode.

Check that the core probe is inserted correctly in the patient and then wait for the Core temperature reading on the screen to stabilize. This may take up to two minutes. Touch **OK** to continue rewarming.

Rewarming at an Unexpected Rate

To troubleshoot for rewarming faster or slower than desired, first:

1. Follow the guidance for Controlled Rewarming Mode on page 44.
2. Confirm the core probe reading on the screen seems accurate by comparing the core and surface values.
3. Confirm that the hourly rewarming rate selected in Settings is appropriate (See page 44).
4. Confirm that no environmental factors are contributing (overhead heating, room temperature, etc.)
5. Confirm that the wrap is properly positioned around the patient.

Then, after verifying the above, consider the following options:

Remaining in Controlled Rewarming Mode, maintain current core temperature for a time by changing the Target Temperature to match it (See Target Temperature Setting on page 43).

Reinitiate Controlled Rewarming Mode by selecting Menu, Mode Select, Controlled Rewarming and reconfirming core temperature when the “Switching to Rewarming” message appears. This will recalculate the RVSP. In version 2.1 and 2.2, it will also result in holding the core temperature for the next step of rewarming.

Rewarm the patient manually by using TTM Mode.

Manual Rewarming

To manually rewarm the patient, use TTM Mode and select a target temperature that is slightly above the core temperature (see Controlled Rewarming Mode on page 44) and wait until the core temperature reaches the new target temperature. Increase the target temperature another step and wait for the core temperature to reach the next step.

NOTE: *The rewarming step and the duration of each step depend on clinical protocols.*

NOTE: *It is recommended to choose steps of 0.2°C - 0.3°C per hour during the rewarming phase.*

Normothermia Mode

User the Normothermia Mode is for warming or cooling a patient in order to achieve or maintain normothermia. The default setpoint of normothermia mode is 36.5°C.

The CritiCool® MINI device operates at the optimal level to obtain the desired set-point temperature.

Exceeding the Normothermia Range

If the desired set point temperature is set to be out of normothermia range (36°C- 38°C/ 96.8°F - 100.4°F), the message **OUT OF NORMOTHERMIA** appears.



Figure 25: Out of Normothermia Message

It is possible to set the patient set point temperature between 30°C- 40°C.

Settings Window

The settings window is divided into five sections and enables the operator to configure various parameters.

NOTE: *The settings window is password protected. Only authorized personnel may change the settings.*

The passcode for the Settings screen is 6873.

To pre-configure the settings:

1. From the Menu panel, choose **Settings**.
2. Enter the password. The settings window appears.
3. Touch the page numbers to move between the pages.
4. Touch **OK** to confirm settings changes and return to the main menu.

Settings Screen 1

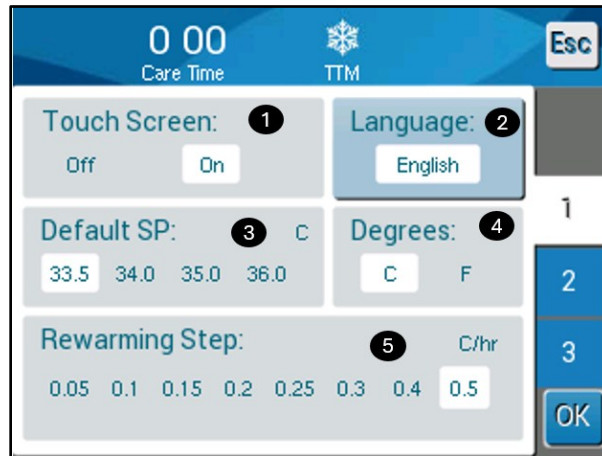

Figure 26: Settings Screen 1

Settings Screen 1 includes:

- Activate or deactivate the touch screen ①.
- Language ②
- Default set point temperature ③
- Temperature scales (Celsius/ Fahrenheit) ④
- Rewarming step for the controlled rewarming mode. ⑤

Settings Screen 2

Settings Screen 2 includes adjustable alarm limits for:

- High patient temperature ①
- Low patient temperature ②
- High water temperature ③

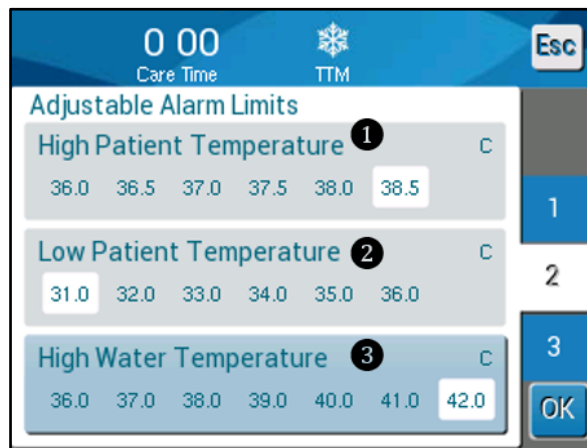

Figure 27: Settings Screen 2

Settings Screen 3

Settings Screen 3 includes the Time and Date:

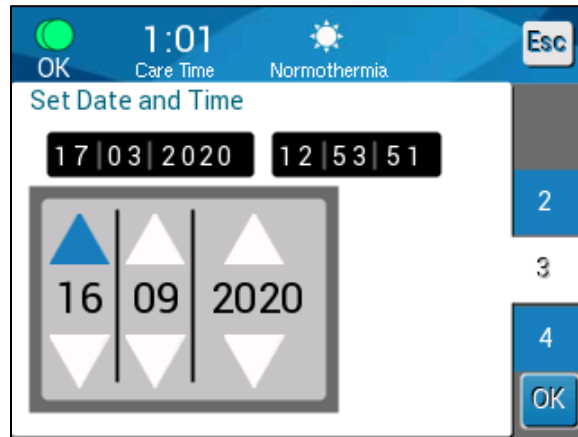

Figure 28: Settings Screen 3

Settings Screen 4

Settings Screen 4 includes a feature for customizing the System ID of CritiCool® MINI. (ex. MINI 12345)

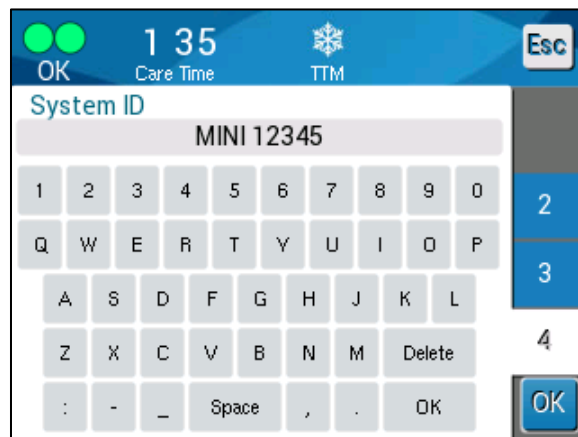

Figure 29: Settings Screen 4

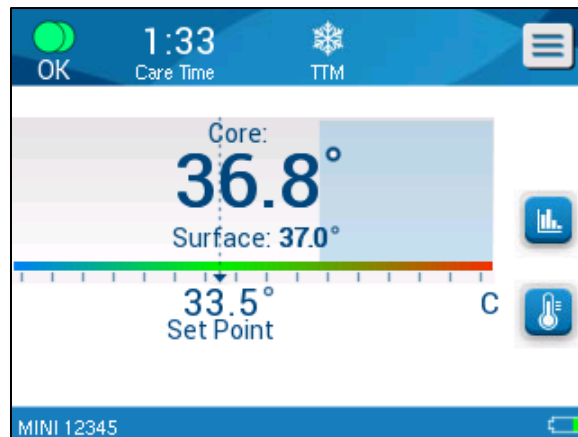

Figure 30: Main Panel with System ID

Set-Point / Target Temperature Set Up

The set-point is the chosen temperature in TTM and Normothermia to which the thermoregulation system cools or warms the patient's body.

The Target Temperature is the chosen temperature in controlled rewarming to which the thermoregulation system warms the body to return the patient to a normothermic temperature.

NOTE: Upon start up, the default set-point for **TTM Mode** is 33.5°C (92.3°F).
Upon start up, the default set point for **Normothermia Mode** is 36.5°C (97.7°F).



After start up, it is possible to change both the Set Point and Target Temperature.

To change the Set Point /Target Temperature

1. Touch the Set Point/Target Temperature icon to display the Set Point/Target Temperature setting screen panel.



Figure 31: Set-Point Setting Screen

2. Use  and  to select the Set Point/Target Temperature to provide a change of 0.1°C. Each tick mark in the scale provides a change of 1.0°C.
3. When finished, touch **OK**.

Temperature Graph

Use the Temp Graph  icon on the menu panel to enter the graphic display of the current or last session.

1. The CritiCool® MINI displays the current case parameters.

If the wrap or the temperature probes are not connected, the last case is displayed.

NOTE: *The Surface (Surf) and Water Out (WOut) Temperature Graphs can be displayed or hidden.*

NOTE: *Water Out (WOut) is only displayed in Software Version 2.1 and 2.2.*

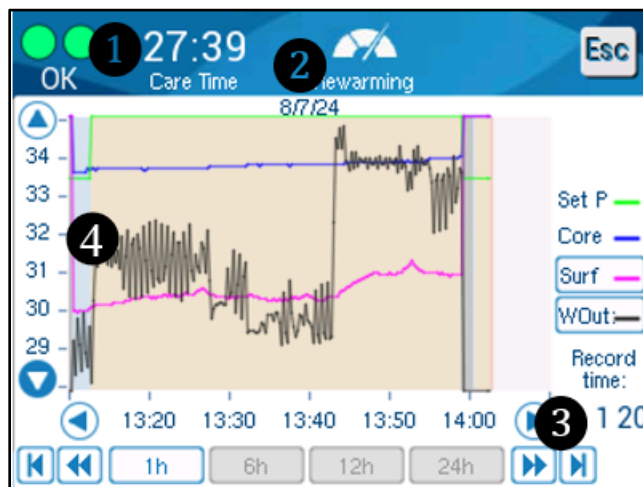

Figure 32: Temperature Graph

2. The date is displayed at the top of the graph.
3. The time from the beginning of the procedure is displayed on the X axis.
4. The temperature is shown on the Y axis. Move forward or backward the time of the graph displayed by using the arrow keys



5. The screen can show 1 hour, 6 hours, 12 hours or 24 hours. Use the double arrows to select the time range.



Services

The Services option is in the Menu panel. Services include the following:

- Empty
- System Check
- Technician
- Thermal Disinfection

The System Check, technician and thermal disinfection are discussed in “Maintenance”.

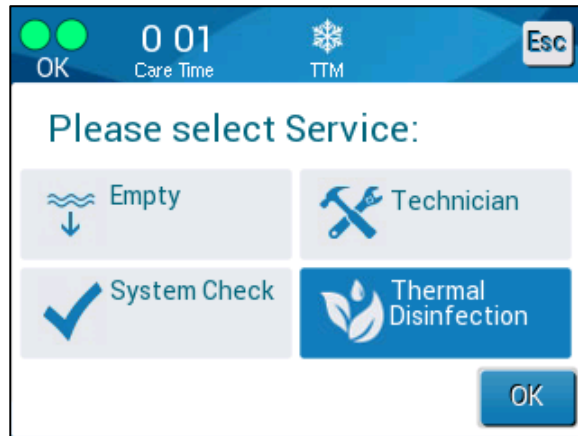

Figure 33: Select Service

Empty

This selection allows for emptying the system of the remaining water, prior to storage of the CritiCool® MINI. This is recommended between cases.

To empty the water tank:

1. Switch to Standby Mode.
2. Disconnect the wrap from the system. Dispose of the wrap.
3. Connect a male draining connector to the "water out" of the CritiCool® MINI and direct the tube to a sink or 2-liter container for water collection.



4. Touch the MENU  icon.
5. Touch services.
 - Touch **Empty**. The following screen appears.
6. When you are ready for the process to begin, touch **Start**. The following screen appears.



Figure 34: Start Emptying Panel

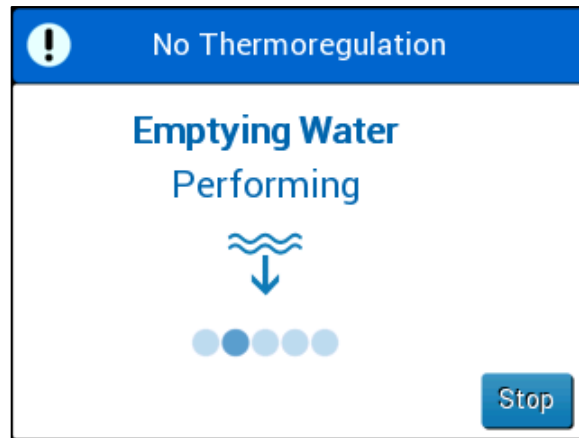

Figure 35: Emptying Water-Performing Panel

7. Wait for the water to drain from the system. When the water has been emptied completely, a message appears stating that the CritiCool® MINI is now ready for storage until the next procedure.

Replacing the Wrap

WARNING! *Avoid disconnecting tubes above electrical equipment as mild dripping may occur during disconnection.*

To replace the Wrap:

1. Switch to STANDBY and wait a minute to let the water return to the system.
2. Close wrap clamps to avoid water spill.
3. Disconnect the connecting tubes from the wrap.
4. Remove the used wrap and dispose of according to hospital regulations.
5. Position the new wrap (follow the instructions for use leaflet supplied with each wrap).
6. Reconnect the connection tubes to the new wrap.
7. When wrapping the patient, follow the instructions for use in the leaflet included with each wrap.

Operation Panel Messages and Alerts

If the wrap's tubes are connected, the temperature probes are connected, and core temperature is measured, water circulation will start without additional user action. If any of the above conditions is not fulfilled, the operation panel message area displays technical and/or clinical alarm messages with a  sign.

NOTE: *Clinical alarms represent medium priority alarms while technical messages represent lower priority alarms.*

NOTE: *Sound pressure of the alarms is 67.5 dba at a distance of 10 centimeters.*

Constant alarms occur in the following states:

- Halt condition
- Select mode screen

The following messages should be checked and confirmed:

- Low core temperature thermoregulation is continuing
- Core readout too low
- Out of normothermia range
- Patient temperature above XX.x°C(*)
- Patient temperature below YY.y°C(*)
- Water temp too high (*)

NOTE: *Only authorized users can change the range of the alarms marked by (*) in the settings screen. The user needs to insert a password to enter the settings panel and change the alarm limit.*

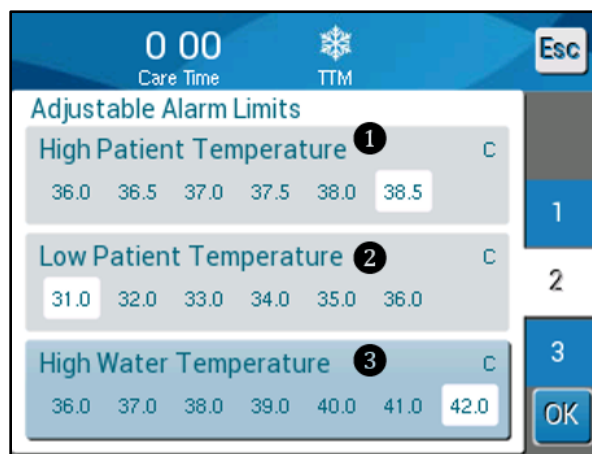

Figure 36: Adjustable Alarm Limits

Safety Messages and Alarms

WARNING! During safety messages, thermoregulation stops.

Safety messages alert the clinician that the system has either overcooled or overheated the circulating water.

The safety messages include:

- WATER TEMPERATURE TOO LOW



- WATER TEMPERATURE TOO HIGH





If such conditions occur, the user should **shut down** the system and find the cause of the problem.



Clinical Messages and Alarms

Clinical messages call for the attention of the clinician (doctor or nurse) and refer to the condition of the patient or call for user confirmation of the setting by touching the **OK** key.

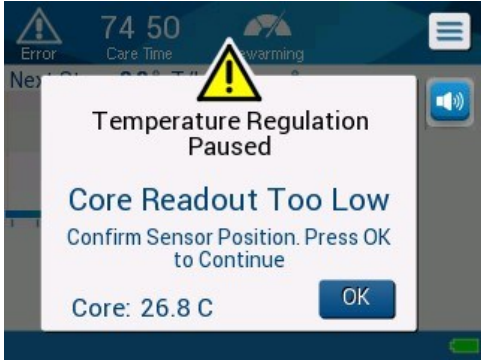
Clinical messages include the following:

Table 5: Clinical Messages

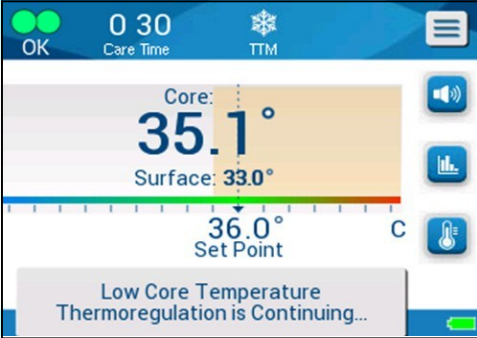
Message	Screen Message	Description
Core Readout Too Low		This message appears when core temperature is at least 2°C lower than Set Point or when the core temperature is below 31°C. An alarm sounds and thermoregulation and water flow stops.
Switching to Auto Rewarm Mode		The alarm can be muted for 5 minutes.
Patient temperature is above 38.5°C		An alarm sounds but thermoregulation continues. The alarm can be muted for 30 minutes.



Message	Screen Message	Description
<p>Low Core Temperature</p>		<p>This message appears when core temperature is $>0.8^{\circ}\text{C}$ less than the set point or according to alarm settings.</p>
<p>Patient's Temperature is below XX.X°C</p>		<p>An alarm sounds but thermoregulation continues.</p>



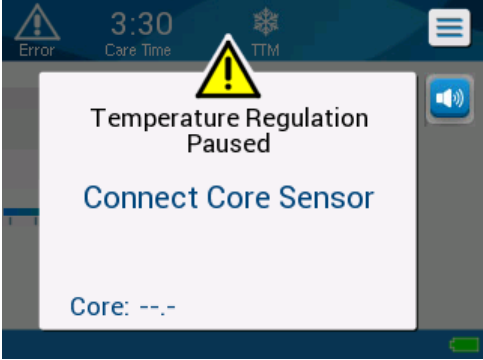
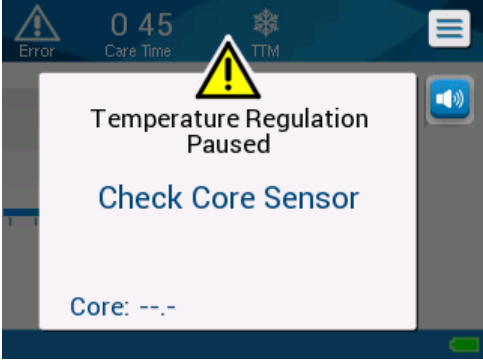

NOTE: *It is possible to change the range of these alarms in the Settings screen. The user can choose at which temperatures the "High Patient Temp" and "Low Patient Temp" alarms will be activated.*

Technical Messages and Alerts

The following technical messages might appear. Follow the instructions of the technical messages to solve the problem. For example, add water if necessary, or connect temperature probes if they are not connected.

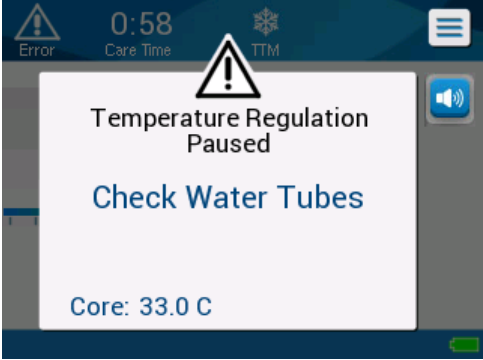
Table 6: Technical Messages and Alarms

Message	Screen Message
Connect core temperature probe	 <p>The screenshot shows a mobile application interface with a dark blue header. On the left, there is an 'Error' icon and '3:30 Care Time'. On the right, there is a 'TTM' icon and a menu icon. A central white alert box contains a yellow warning triangle icon, the text 'Temperature Regulation Paused', and the instruction 'Connect Core Sensor'. At the bottom of the alert box, it says 'Core: --.'. A speaker icon is visible on the right side of the alert box.</p>
Check core temperature probe	 <p>The screenshot shows a mobile application interface with a dark blue header. On the left, there is an 'Error' icon and '0:45 Care Time'. On the right, there is a 'TTM' icon and a menu icon. A central white alert box contains a yellow warning triangle icon, the text 'Temperature Regulation Paused', and the instruction 'Check Core Sensor'. At the bottom of the alert box, it says 'Core: --.'. A speaker icon is visible on the right side of the alert box.</p>
Connect connecting water tubes	 <p>The screenshot shows a mobile application interface with a dark blue header. On the left, there is an 'Error' icon and '0:27 Care Time'. On the right, there is a 'TTM' icon and a menu icon. A central white alert box contains a yellow warning triangle icon, the text 'Temperature Regulation Paused', and the instruction 'Connect Water Tubes'. At the bottom of the alert box, it says 'Core: --.'. A speaker icon is visible on the right side of the alert box.</p>

Message	Screen Message
Check water tubes	 <p>The screenshot shows a dark blue header with an 'Error' icon, 'Care Time' at 0:58, and a 'TTM' icon. A white message box contains a warning icon, the text 'Temperature Regulation Paused', 'Check Water Tubes', and 'Core: 33.0 C'. A speaker icon is on the right.</p>
Low battery, connect to power supply	 <p>The screenshot shows a dark blue header with an 'Error' icon, 'Care Time' at 1:16, and a 'TTM' icon. A white message box contains a warning icon, the text 'Thermoregulation is Continuing...', 'Low Battery. Connect to Power Supply', and 'Core: 33.0 C'. A speaker icon is on the right.</p>
Add water	 <p>The screenshot shows a dark blue header with an 'Error' icon, 'Care Time' at 7:05, and a 'TTM' icon. A white message box contains a warning icon, the text 'Temperature Regulation Paused', 'Add Water', and 'Core: 33.5 C'. A speaker icon is on the right.</p>
Tank is empty	 <p>The screenshot shows a dark blue header with an 'Error' icon, 'Care Time' at 6:50, and a 'TTM' icon. A white message box contains a warning icon, the text 'Temperature Regulation Paused', 'Tank is Empty', and 'Core: 36.0 C'. A speaker icon is on the right.</p>



Informative Messages



Informative messages indicate the status of the machine.

These messages are for information only and do not require any user response. The message appears at the bottom of the main screen.

The informative messages include:

Table 7: Informative Messages

Message	Screen Message	Description
<p>Body temperature in accepted range</p>		<p>Appears when core temperature reaches an accepted core temperature.</p>
<p>Thermoregulation is continuing...</p>		<p>Appears after confirming low core temperature for five seconds.</p>
<p>Holding Core Temperature for the First Step of Rewarming</p> <p>This message is only displayed in Software Version 2.1 & 2.2.</p>		<p>This message appears upon initiating Controlled Rewarming Mode after the Switching to "Auto Rewarm" message appears.</p>

Message	Screen Message	Description
<p>Target Temperature Has Been Reached</p> <p>This message is only displayed in Software Version 2.1 & 2.2.</p>		<p>This message displays in Controlled Rewarming Mode when the core temperature reaches Target Temperature.</p>
<p>Out of Normothermia Range</p>		<p>Appears when a set point temperature is chosen <32°C or >38.0°C (outside of Normothermia Range).</p> <p>Touching OK confirms the new set point temperature and removes the message</p>
<p>No Battery Connected</p> <p>This message is only displayed in Software Version 2.1 & 2.2.</p>		<p>Appears when battery is not connected, no functionality on battery.</p>

TTM Mode Messages

The thermoregulation system may have one of three conditions:

1. Core Temperature above the Set Point [$T_c \geq T_{sp} - 0.8^\circ\text{C}$]

In this condition, temperature control starts without further user action.

2. Core Temperature is above 31°C but lower than the Set Point by 0.8°C [$31^\circ\text{C} < T_c < (T_{sp} - 0.8)$] or the core temperature is lower than the preset low patient temperature alarm.

In this condition, temperature control continues and warms the patient toward the set point.

An informative message appears and an audible alarm will sound. Pressing MUTE stops the audible alarm for 30 minutes. The written message on the screen is removed only when the $\Delta \leq 0.6^\circ\text{C}$.



Figure 37: Low Core Temperature Alarm

3. Core temperature is lower than the set point by more than 2°C ($\Delta(T_{sp} - T_{core}) > 2^\circ\text{C}$) or if $T_c < 30.8^\circ\text{C}$

This message could indicate that the core temperature probe might be out of place.

The following message appears: “Temperature Regulation Paused. Core Readout too Low. Confirm Sensor Position. Press OK to continue.”

An audible alarm also sounds.

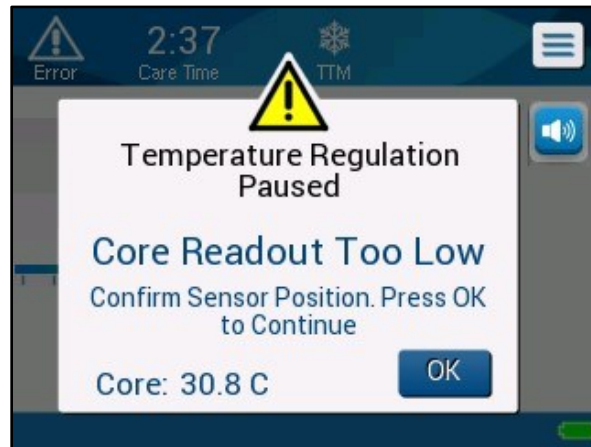

Figure 38: Temperature Regulation Paused – Core Readout Too Low Message

Touching the hard key next to the Alarm icon  will mute the alarm for **five** minutes but leave the message on the screen.

NOTE: *If the temperature is below 30.5°C, the alarm cannot be silenced.*

NOTE: *If the user disregards the message and does not touch OK for over 30 minutes, the alarm cannot be silenced.*

While the message appears, thermoregulation is paused and the machine switches into standby mode (water stops flowing to the wrap).

Check that the core temperature probe is in place and the low temperature represents the true patient status and then touch **OK** to re-activate temperature control.

When **OK** is touched, the screen returns to the main screen and the following message appears for 5 seconds.

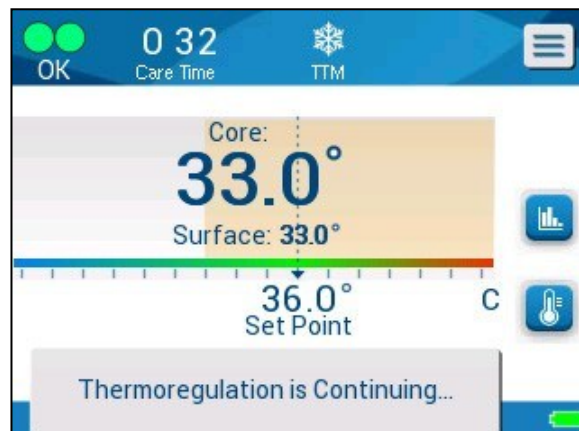

Figure 39: Thermoregulation is Continuing Message

This message indicates that water is now flowing into the wrap and that thermoregulation is continuing.

Once **OK** has been touched, the Temperature Regulation Paused message will reappear every 30 minutes that its alarm conditions are met.

Controlled Rewarming Mode Messages

During Controlled Rewarming, there may be two conditions:

1. Virtual Set Point (VSP) Temperature - Core Temperature > 0.8°C and <2°C:

In this case, a message appears with an alarm, but thermoregulation continues.

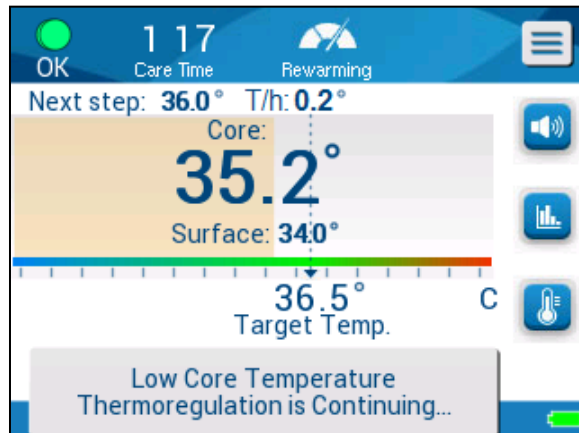

Figure 40: Low Core Temperature Alarm

2. Patient Core Temperature < Target Temperature and (Δ Virtual SP-Core Temp) >2°C

This means that the core temperature probe is probably out of the body. The following message appears, and an audible alarm sounds:

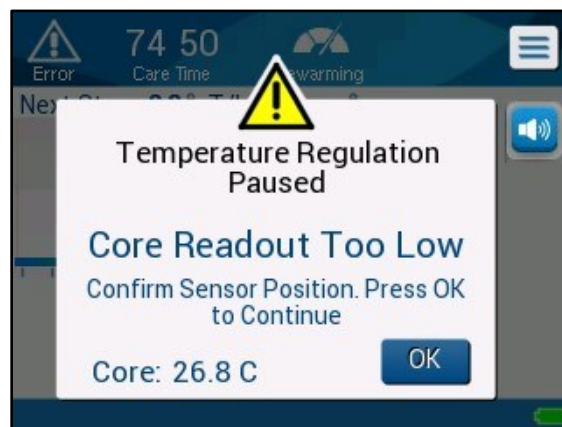

Figure 41: Core Readout too Low Message

Pressing MUTE disables the audible tone. The alarm restarts after **5** minutes.

While the message “Core Readout Too Low” appears, the machine is not regulating the patient's temperature and no water is flowing to the wrap.

Check that the core temperature probe is in place and the low temperature represents the true patient status, then touch **OK** to re-activate temperature control.

NOTE: If the user disregards the message and does not touch **OK** for over 30 minutes, **the alarm cannot be silenced.**

When **OK** is touched, the screen returns to the Main Screen and the following message appears for 5 seconds.

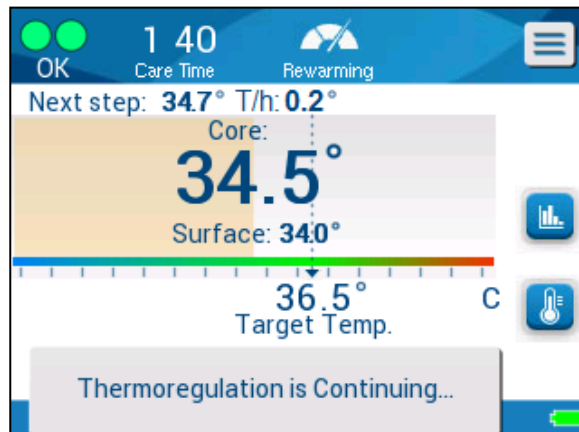

Figure 42: Thermoregulation is Continuing Message

Chapter 5: Ordering Information

Equipment and Accessories

All equipment and accessories may be ordered directly from Belmont Medical Technologies or your local authorized distributor. When ordering parts, specify the part number as listed in this chapter as well as the serial number of your CritiCool® MINI device.

Available Wraps

Models for various wraps are available. See below.

Table 8: Wrap Ordering Information

	Part number	Number of wraps per package	Patient Size/ Weight	Wrap Length/ Width (m)
CureWrap® Infant	508-03518	8/Box	2.5-4.0 Kg	0.659/0.448
	508-03521	8/Box	4.0-7.0 Kg	0.698/0.602
CureWrap® Infant Assorted	PED-SM008	8/Box	4/2.5-4.0 Kg	0.659/0.448
	500-03518	4/Box	4/4.0-7.0 Kg	0.698/0.602
	500-03521	4/Box		

Available Accessories

One accessory kit is provided with each device. The CritiCool® MINI Accessory Kit is available in two configurations: one with reusable temperature probes (PN# 200-00200) and one with adapter cables for use with disposable temperature probes (PN# 200-00201). Refer to Table 9 and Table 10.

Disposable temperature probes need to be ordered separately. Table lists common accessories that can be ordered individually.

Table 9: CritiCool® MINI Accessory Kit with Reusable Probes

Sub Part No.	Description	Number Supplied
014-00005	Reusable Core Temperature Probe Infant, Gray	1
014-00021	Reusable Surface Temperature Probe, Green	1
200-00109	Connecting Water Tubes, 2 by 2 Way	1
200-R0130	Filter Unit (internal)	1
014-00012	Reusable Temperature Probe Adaptor	1
DDT320002	CritiCool® MINI Step by Step Guide, English	1
405-00021	CritiCool MINI Disinfection Kit	1

Table 10: CritiCool® MINI Accessory Kit for Disposable Probes

Sub Part No.	Description	Number Supplied
014-00028	Adapter Cable for Disposable Core Temperature Probes, Gray, Molex	1
014-00324	Adapter Cable for Disposable Surface Temperature Probes, 3.5mm (1/8") Mono Socket, Green	1
200-00109	Connecting Water Tubes, 2 by 2 Way	1
200-R0130	Filter Unit (internal)	1
014-00012	Reusable Temperature Probe Adaptor	1
DDT320002	CritiCool® MINI Step by Step Guide, English	1
405-00021	CritiCool MINI Disinfection Kit	1

Table 11: Accessories

Part number	Description
014-00035	Disposable Core Temperature Probe, 9 Fr, Smiths Medical ER400-9 (20/pack)
014-00036	Disposable Core Temperature Probe, 7 Fr, Metko FMT400/AOR-D2 (40/pack)
014-00323	Disposable Surface Temperature Probe, 3.5mm (1/8") Mono Jack (50/pack)
002-00069	Male Connector for Draining Water Tank (25/pack)
200-R0130	Filter Unit (internal)
017-00250	CliniLogger™ assembly
200-00109	Connecting Water Tubes, 2 by 2 Way
014-00005	Reusable Core Temperature Probe Infant, Gray
014-00021	Reusable Surface Temperature Probe, Green
014-00028	Adapter Cable for Disposable Core Temperature Probes, Gray, Molex
014-00324	Adapter Cable for Disposable Surface Temperature Probes, Green, 3.5mm (1/8") Mono Socket

Chapter 6: Maintenance

Introduction

This chapter outlines the maintenance instructions for the CritiCool® MINI system. Trained hospital staff may perform routine maintenance unless otherwise specified.

WARNING! *The repair and servicing of the CritiCool® MINI system should be performed only by Belmont Medical Technologies or authorized agents of Belmont Medical Technologies.*

Service Information

When communicating with authorized Belmont Medical Technologies representatives regarding the CritiCool® MINI system, please provide the software version and serial numbers on the identification label located on the rear panel of the CritiCool® MINI device.

When communicating regarding wraps, refer to the label on the wrap package for lot number details.

Replacement of the battery should only be made by a certified Belmont Medical Technologies service engineer.

Routine & Preventative Maintenance

The CritiCool® MINI device should be inspected and maintained to make sure that it remains in optimum condition, prior to use as noted in Table 12.

Table 12: Recommended Routine Inspection and Maintenance Schedule

Frequency	Inspection/Service	Performed By
Before each use	<ul style="list-style-type: none"> • Clean connecting tubes, Quick Coupling Connectors, and reservoir cap with a wet cloth. • Perform a visual inspection for any mechanical failure in probes, connecting tubes, and power cable. • Perform a visual inspection of the exterior of the CritiCool® MINI Device. 	Clinician or Hospital Staff
As required by hospital/clinic protocol	<ul style="list-style-type: none"> • Routine external cleaning and disinfecting. • Replace Connecting Water Hoses (PN #200-00109) periodically. 	Clinician or Hospital Staff
Per instructions found in: "2.DISINFECTION FREQUENCY "	<ul style="list-style-type: none"> • Disinfect water circuit. 	Clinician or Hospital Staff
Annually	<ul style="list-style-type: none"> • Yearly Maintenance • Replace filter * • Thermal Disinfection (optional) 	Belmont Medical Technologies authorized technician

* Filter replacement could be performed more frequently than once a year (according to water quality) if needed.

Routine Maintenance Overview

Cleaning and disinfection of the external surface and the water reservoir of the system should be done before each use of the device. The system components may be contaminated during use and storage of the device from numerous factors.

CAUTION!

- Do not use any kind of brush on the machine touch screen or its accessories.
- Do not submerge the machine in liquid.
- Do not wash the electrical power socket.
- Do not use any saline or irrigated fluids.
- Do not use any ester solvents.

For reusable temperature probes, follow the manufacturer's recommendations and always check the temperature probes for scratches and tears before and after cleaning. If the probe is damaged, do NOT use it.

NOTE: Follow your hospital protocols for disinfecting the product.

Cleaning & Disinfecting External Surfaces

Required Tools for Cleaning of External Surfaces

- PPE (Personal Protective Equipment) according to the disinfectant manufacturer's instructions.
- Lint free cloths.

Recommended Disinfectants for External Surfaces

- Chlorinated bleach solution (5.25% sodium hypochlorite concentration)
- Quaternary ammonium compounds (ammonium chloride as active ingredient)

Before Each Use

CAUTION! *Apply finger pressure only. External instruments exert excessive pressure on the screen and should not be used.*



1. Use PPE as recommended by the disinfectant's manufacture.
2. Make sure that the system is turned off and unplugged from power.
3. Using a lint free cloth with sterile water, clean the exterior of the machine and the LCD screen from any soiling.
4. Prepare the disinfectant solution as described by the manufacturer and follow the manufacturer's directions for time duration and concentration.
5. Using a lint free cloth with the disinfectant, disinfect the exterior of the machine, the LCD screen, and the hoses.
6. For residue removal, use a new lint free cloth moistened with sterile water. Use the cloth on the exterior of the system, the screen, and the hoses.

Cleaning, Disinfecting and Sterilization of the Reusable Temperature Probes

The cleaning, disinfection and sterilization of the reusable temperature probes are according to the manufacturer's instruction.

Disposable probes are not to be reused. Improper use can lead to cross contamination and deterioration of safety.

Water Circuit Disinfection Instructions

1. REQUIRED TOOLS FOR DISINFECTION				
A.	CritiCool® MINI Disinfection Kit (P/N 405-00021) includes:			
	2-Connector Bypass Tube	P/N 200-00181		
	Temperature Simulator	P/N 017-00245		
B.	PPE (Personal Protective Equipment) per the NaDCC tablet manufacturer's instructions.			
C.				Sodium Dichloroisocyanurate (NaDCC) tablets in the recommended concentration
D.	Hospital-grade disinfecting wipes			
E.	Sterile water / 0.22µm filtered water (approximately 2 Liters total)			<i>NOTE: Do not use de-ionized water or water created through reverse osmosis as it may promote corrosion of the metal components of the system.</i>

2. DISINFECTION FREQUENCY
Prior to First Use
At Least Once Every 3 Months
Before Long-Term Storage (>3 Months)
Before Use Following Long-Term Storage (>3 Months)

NOTE: Disinfection can be performed more frequently if the hospital protocol dictates.



NOTE: If a patient, clinician, or biomatter comes in contact with the water circuit disinfect immediately after.





NADCC CONCENTRATION RECOMMENDATIONS

Tablets needed to achieve at least a 5382 ppm concentration of NaDCC

PurTabs® (3.3g)	Klorsept® 17 (3.4g)	Aquatabs® (1.67g)
6 Tablets per 1 L of water	6 Tablets per 1 L of water	6 Tablets per 1 L of water

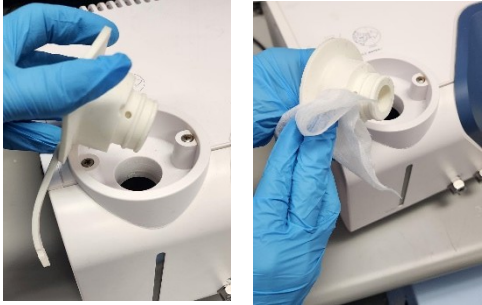



3. DEVICE PREPARATION AND DISINFECTION

A.	 <p>Fill to appx. 1.5 cm from the top</p>	<p>Ensure the device is powered OFF. Check the water tank level. Add room temperature sterile or 0.22µm filtered water until the water level is approximately 1.5 cm from the top of the fill indicator to ensure the machine has 1 L.</p> <p><i>NOTE: Alternatively, you can prepare this disinfection solution in a separate container per the NaDCC tablet manufacturer's instructions.</i></p>
	<p>PPE Required</p>	<p>Use the appropriate PPE per the NaDCC tablet manufacturer's instructions for use.</p>
B.	<p>Add NaDCC</p>	<p>Remove the cap from the device's water tank. Procure the appropriate NaDCC tablets and add 6 tablets to the device's water tank (see above).</p> <p><i>NOTE: Do not disinfect the water circuit near the area of care.</i></p>
C.		<p>Allow the tablets to dissolve for 15 minutes.</p> <p>While tablets are dissolving, perform the remaining steps in Step C.</p> <p><i>NOTE: Do not leave the dissolved tablet solution in the device's water tank for more than 20 minutes.</i></p>

	<p>2-Connector Bypass</p>  <p>P/N 200-00181</p>	 <p>Wipe clean the cap with hospital-grade disinfecting wipes, then reattach the cap.</p>	<p>Connect the blue hoses (P/N 200-00109) to the 2-connector bypass tube assembly (P/N 200-00181). Connect the other ends of the blue hoses to the device.</p>
<p>D.</p>	<p>Plug in the device, power it ON, and allow the Self-Test to complete.</p>		
<p>E.</p>		<p>Select and operate the device in Normothermia mode. Set the patient setpoint to 37°C.</p>	
<p>F.</p>		<p>Plug the temperature simulator (P/N 017-00245) into the Core temperature socket on the front of the device and set it to 36.0°C ±0.3 by turning the dial and watching the display.</p>	
<p>G .</p>		<p>Allow the solution to circulate for 5 minutes (minimum) to 6 minutes (maximum) to disinfect the device's water circuit.</p> <p>Place the device into Stand-by mode once completed.</p>	
<p>H.</p>	<p>Remove the bypass tube assembly from the connected blue hose set. Drain the solution from the device's water tank following the instructions per Chapter 4: To empty the water tank. Dispose of the cleaning solution per hospital protocol.</p>		
<p>I.</p>	<p>Flush Cycle</p>	<p>Proceed to Section 4 "Flush Cycle" to complete the disinfection and cleaning procedure.</p>	

4. FLUSH CYCLE

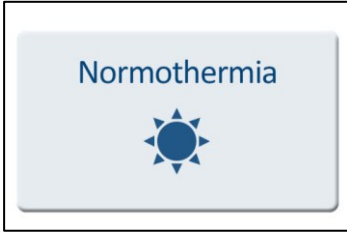
NOTE: Device **MUST** be flushed. If the device is not flushed, damage to the device's internal components may occur.

A.		Refill the device with 1 L of sterile or 0.22µm filtered water (no NaDCC).	
B.		Reconnect the bypass tube assembly to the blue hoses still connected to the device.	
C.			Place the device back into Normothermia mode with the temperature simulator still set to 36.0°C ±0.3. Allow the water to circulate for at least 5 minutes before placing the device in Stand-by mode.
D.	Remove the bypass tube assembly from the connected blue hose set. Drain the solution from the device's water tank following the instructions per Chapter 4: To empty the water tank . Refill the device with 1.2 L of room temperature sterile or 0.22µm filtered water if returning to use or leave tank empty if moving to storage .		
E.	Power OFF the device, unplug it and disconnect the blue hoses. Disconnect and store the temperature simulator (P/N 017-00245).		

DEVICE IS NOW READY FOR STORAGE OR NEXT PATIENT

NOTE: This document does not replace the requirement to read the entire device user manual. For complete operations, maintenance and cleaning instructions, please refer to the device user manual.

Thermal Disinfection Process (Self-Cleaning)

This feature performs a thermal disinfection of the water tank and internal tubing and is optional.

The thermal disinfection of CritiCool® MINI is an integrated feature, which heats the circulating water of the system, thus allowing the heat to disinfect the internal water pathways of the system, including the water tank.

Required Equipment

- Bypass tube PN #200-00181 or PN #200-00096
- Up to 1.2 liters of sterile or 0.22 µm filtered water

To perform Thermal Disinfection:

Make sure that water tank is full, and the bypass tube is connected.

1. In the main menu, select **Services**.

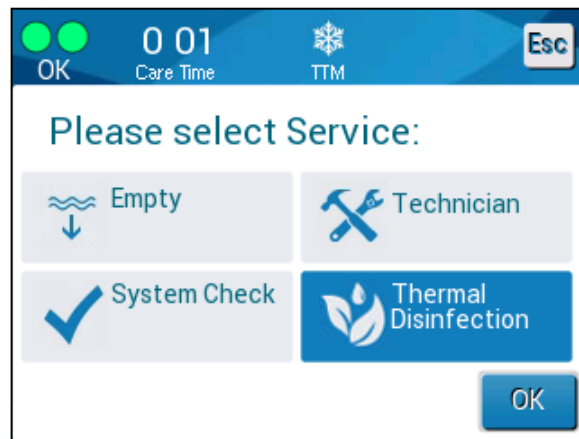

Figure 43: Selecting Thermal Disinfection Service

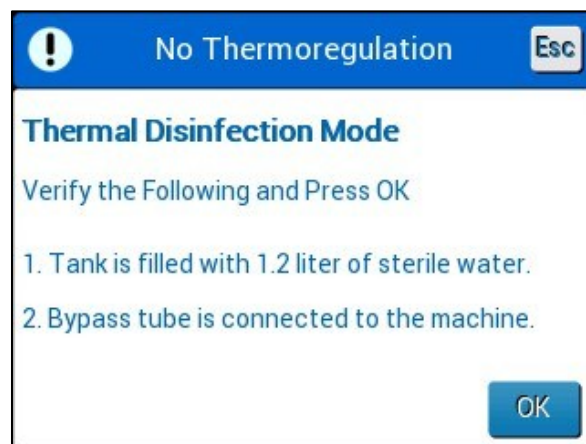

Figure 44: Initiating Thermal Disinfection

2. Touch Thermal Disinfection and then OK.
3. The process is password protected. Enter password.

4. Touch OK. The following verification message appears:
5. Verify that the tank is full. Connect the bypass tube and touch OK. Thermal Disinfection begins. Countdown appears on the screen.

The process takes about 2 to 3 hours.

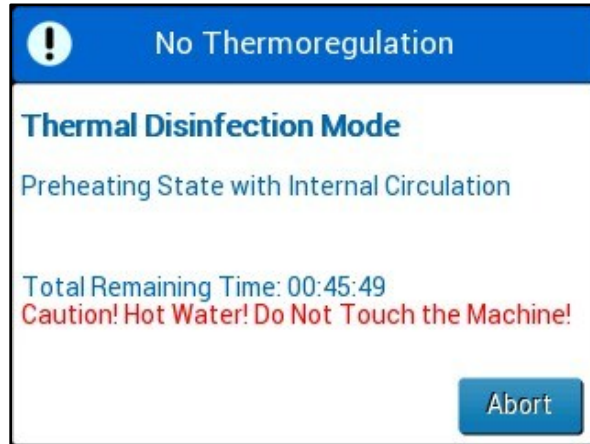

Figure 45: Thermal Disinfection Mode

CAUTION! Do not touch the machine or hoses during the self-cleaning process as they are **HOT**.

NOTE: For more information, refer to the Service Manual.
Use only sterile water or 0.22 micron filtered tap water.
Always drain the water after the thermal disinfection process.

System Check Service

The System Check service is initiated from the Services menu.

The System Check service performs a complete check of the system by checking the functionality of the following components:

- Screen and buzzer
- Pump
- Wrap connection
- Pressure meter
- Heating and cooling unit
- Temperature of water inflow and water outflow

Successful completion of the System Check service indicates that the CritiCool® MINI device is operational.

NOTE: If CritiCool® MINI was out of use for an extended period, it is recommended to perform a full System Check.

To perform system check:

NOTE: Before performing System Check, verify that the water tank is full.

1. In the main menu, select **Services**. The following window appears.



Figure 46: Selecting System Check

2. In the Services screen, select **System Check** then click **OK** to confirm. A message appears requesting you to confirm start of System Check.
3. Touch **start**.

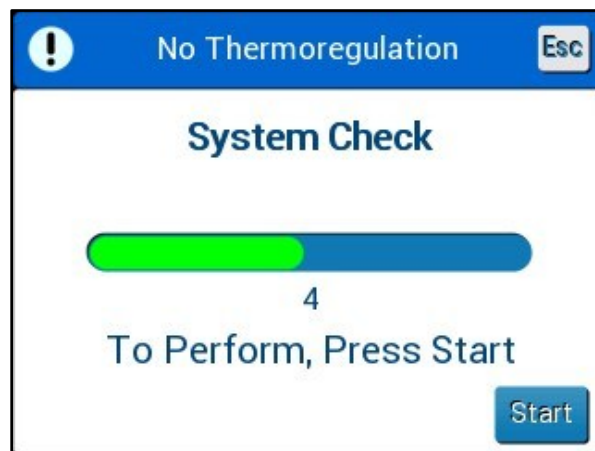

Figure 47: System Check in Progress

System Check is initiated. The progress bar that appears on the screen indicates the progress. System Check takes about 10 minutes.

When the process is complete, a message appears on the screen "SYSTEM CHECK COMPLETED".

4. Switch to the Operation screen.
5. Turn CritiCool® MINI off.

Filter Replacement

The filter is for filtering hard solids or large particles and it is not intended for filtering the water from bacterial contamination.

The filter must be replaced every twelve months at a minimum.

NOTE: *The filter should be replaced only by Belmont Medical Technologies authorized personnel / authorized biomedical personnel. See the Service Manual for replacement instructions.*



Chapter 7: Troubleshooting

General

CritiCool® MINI is equipped with self-testing routines that continuously monitor system operation. If a system fault or malfunction is detected, a fault message appears. Should a malfunction occur, consult the Troubleshooting Guide.

Troubleshooting Guide

Table 13: CritiCool MINI System Malfunction (No Message) Troubleshooting Guide lists some possible scenarios that may indicate a malfunction, their cause, and recommended actions.

Table 14: Water Tank Overfilling lists water tank overfilling troubleshooting.

Table 15: CritiCool MINI System Message Troubleshooting Guide provides a list of fault messages that appear on the CritiCool® MINI screen.

CAUTION! *The repair and servicing of the CritiCool® MINI system should be performed only by Belmont Medical Technologies or authorized agents of Belmont Medical Technologies.*

Table 13: CritiCool MINI System Malfunction (No Message) Troubleshooting Guide

Observation	Possible Problem	Action to be Taken
The power switch of CritiCool® MINI is set to "ON" but it is not activated, and the control panel is blank.	CritiCool® MINI is unplugged.	Check the power cable connections.
	No line voltage	Call Biomedical Department.
Wrap begins to leak.	The wrap was accidentally punctured during the course of the operation.	Turn off the CritiCool® MINI and allow the water to return to the reservoir. Replace the Wrap if possible.
Water leaks from the connector between Wrap and the connecting tube.	Connecting tubes are not sealed properly.	Close clamps on Wrap. Disconnect connecting tubes and re-connect connecting tubes until the click sound is heard.
	Damage to connecting tubes.	Replace connecting tubes.
	Damage to quick coupling connector.	Call Biomedical Department.
Water leaks between connecting tubes and CritiCool® MINI.	Connecting tubes are not connected properly.	Disconnect connecting tubes from the machine and re-connect again until the click sound is heard.
	Damage to connecting tubes.	Replace connecting tubes.
	Damage to quick coupling connector.	Call Biomedical Department.

Table 14: Water Tank Overfilling











Observation	Action to be taken
Water tank overfilled	<p>It is necessary to drain the water tank after each use to avoid overfilling:</p> <ol style="list-style-type: none"> 1 Connect one end of the CureWrap® connecting tubes to the right quick coupling connector. <p>Or</p> <p>Connect the <i>gray-colored</i> end of the CureWrap® connecting tube to the right quick coupling connector.</p> <ol style="list-style-type: none"> 2 Connect the special male connector to the connecting tube (see below). 3 Turn on CritiCool® MINI. 4 Select Empty mode in Services. 5 Allow the excess water to drain into a receptacle, pail or sink. 6 When the desired water level has been reached, turn off CritiCool® MINI.
	

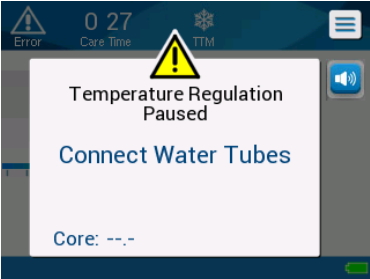
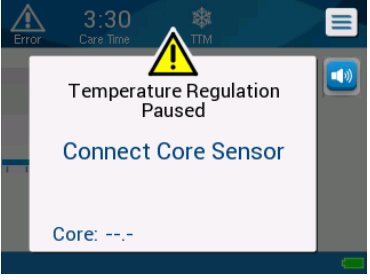
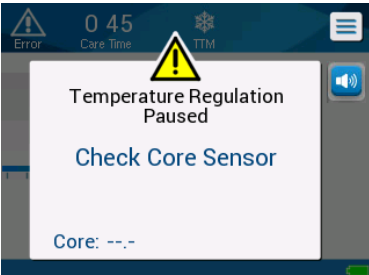

Table 15: CritiCool MINI System Message Troubleshooting Guide

Message	Cause of Problem	Action to be taken	Comments
 Indicates that an alarm is activated			
<p>Tank is Empty</p> 	<p>No water in the tank. Water tank float is jammed</p>	<p>Open water tank cap. Refill water tank to the maximum. Insert a long object to release the float.</p>	
<p>Add Water</p> 	<p>Water level is too low</p>	<p>Refill water tank to the maximum.</p>	<p>The alarm can be muted for an unlimited time.</p>
<p>Connect Water Tubes</p> 	<p>Connecting tubes are not connected.</p>	<p>Connect connecting tubes. Check for creases, folds, or objects that obstruct the water flow in the wrap. Check clamps.</p>	<p>* Pressing alarm mute silences the buzzer for 30 minutes.</p>
<p>Connect Core Temperature Probe</p> 	<p>No core temperature probe is inserted in its socket.</p>	<p>Connect core temperature probe</p>	<p>* Pressing alarm mute silences the buzzer for 30 minutes.</p>

Message	Cause of Problem	Action to be taken	Comments
	<p>Wrap is blocked due to improper wrapping. Wrap clamps are closed.</p>	<p>Check for creases, folds, or objects that obstruct the water flow in the wrap. Check clamps.</p>	<p>* Pressing Alarm Mute silences the buzzer for 30 minutes.</p>
	<p>Misplacement of core temperature probe in core socket. Core temperature probe's adapter is connected to CritiCool® MINI without the temperature probe.</p>	<p>Connect the core temperature probe to the appropriate socket. Connect disposable temperature probe to the adapter and insert into the patient.</p>	<p>This alarm cannot be muted.</p>
	<p>The battery of CritiCool® MINI has no power.</p>	<p>CritiCool® MINI should be attached to a power supply.</p>	<p>This alarm cannot be muted.</p>
	<p>Core temperature is at least 2°C lower than Set Point – or the core temperature is below 31°C.</p>	<p>Confirm the location of the core temperature probe. Press OK to continue.</p>	<p>An alarm issues and thermoregulation stops. The alarm can be muted for 5 minutes. NOTE: If you disregard the message and do not touch OK for over 30 minutes, the alarm cannot be silenced until the OK button is touched. When OK is touched, the screen returns to the Main Screen and a message appears for 5 seconds indicating that thermoregulation has resumed.</p>

Message	Cause of Problem	Action to be taken	Comments
<p>Switching to autorewarm Mode</p> 	<p>Confirmation of the patient's core temperature before changing to Controlled Rewarming mode.</p>	<p>Confirm the patient's temperature. Once confirmed, press OK to continue.</p>	<p>This alarm cannot be muted.</p>
<p>Holding Core Temperature for the First Step of Rewarming</p> 	<p>This message appears upon initiating Controlled Rewarming Mode after the Switching to "Auto Rewarm" message appears.</p>	<p>Follow the patient's temperature.</p>	<p>In Software Version 2.1 and 2.2, core temperature is maintained for the first rewarming step, which lasts from 0.5 to 2.0 hours, and this message displays for 30 minutes. This message only displays in Software Version 2.1 and 2.2.</p>
<p>Target Temperature Has Been Reached</p> 	<p>This message displays in Controlled Rewarming Mode when the core temperature reaches Target Temperature.</p>	<p>Inform the clinician. If continuing thermoregulation initiate Normothermia Mode via Mode Select.</p>	<p>This message displays for 30 minutes. This message only displays in Software Version 2.1 and 2.2.</p>
<p>Water Temperature Too Low</p> 	<p>Water temperature in the system is less than 10°C (50°F).</p>	<p>Thermoregulation stops. Turn OFF the system for 3 seconds and then turn it ON again. If the problem persists, Turn OFF CritiCool® MINI and contact a Belmont Medical Technologies representative.</p>	<p>The alarm can be muted for unlimited time.</p>

Message	Cause of Problem	Action to be taken	Comments
<p>Water Temperature Too High</p> 	<p>When the water temperature in the system is more than 42°C (107.6°F).</p>	<p>Thermoregulation stops until the water cools or the system halts.</p> <p>Turn OFF the system for 3 seconds and then turn it ON again. If the problem persists,</p> <p>Turn OFF CritiCool® MINI and contact your Belmont Medical Technologies representative.</p>	<p>The alarm can be muted for unlimited time.</p>
<p>Patient's temperature is above XX.X°C</p> 	<p>The alarm for High Patient Temperature can be configured in "settings". The alarm and message are issued according to the selected alarm limit.</p> <p>The available values are: 36°C, 36.5°C, 37°C, 37.5°C, 38°C, 38.5°C</p>	<p>Check that the core temperature probe is in place and follow the patient's temperature.</p> <p>Inform the clinician.</p>	<p>Thermoregulation continues.</p> <p>The alarm can be muted for 30 minutes.</p>
<p>Low Core Temperature Thermoregulation is Continuing..</p> 	<p>This message appears:</p> <ol style="list-style-type: none"> 1. When Core temp. Is >0.8°C less than the Set Point. 2. According to alarm settings. 	<p>Check that the core temperature probe is in place and keep following the patient's temperature.</p> <p>No action is required.</p> <p>If rewarming manually: Do not attempt to increase more than 0.8°C above actual core temperature.</p>	<p>For this message, an alarm issues but thermoregulation continues.</p> <p>The alarm can be muted for 30 minutes.</p>

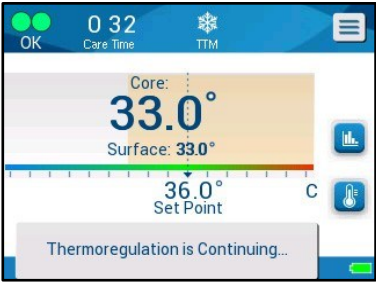
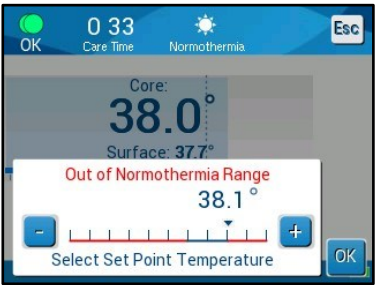
Message	Cause of Problem	Action to be taken	Comments
<p>Patient's temperature is below XX.X°C</p> 	<p>Core temperature is below the alarm limit preconfigured in the settings panel.</p> <p>The alarm and message are issued according to the selected alarm limit. The available values are: 31°C, 32°C, 33°C, 34°C, 35°C, 36°C.</p>	<p>Check that the core temperature probe is in place and follow the patient's temperature.</p> <p>Inform the physician.</p>	<p>Thermoregulation continues.</p> <p>The alarm can be muted for 30 minutes.</p>
<p>Body temperature in accepted range</p> 	<p>Core temperature reaches an acceptable core temperature.</p>		<p>The message appears for 5 seconds.</p>
<p>Thermoregulation is Continuing..</p> 	<p>CritiCool MINI has left an alarm state and returned to a normal operation mode.</p>	<p>Confirm patient's temperature.</p>	<p>The message appears for 5 seconds.</p>
<p>Out of Normothermia Range</p> 	<p>Set Point Temperature for Normothermia is <32°C and >38.0°C.</p> <p>For this message, thermoregulation continues.</p>	<p>Touch OK to confirm the new set point temperature and to eliminate the message.</p>	<p>No alarm.</p>

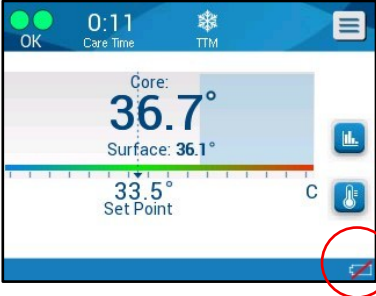
Message	Cause of Problem	Action to be taken	Comments
<p>No Battery Connected</p>  <p>The screenshot shows a medical device interface with a blue header. It displays 'Core: 36.7°', 'Surface: 36.1°', and 'Set Point: 33.5° C'. A red circle highlights a crossed-out battery icon in the bottom right corner of the screen.</p>	<p>Battery is not connected, no functionality on battery.</p>	<p>Ensure the battery connector is securely attached. If it is disconnected, reconnect it to restore battery functionality.</p>	<p>No alarm, no message on screen, only the battery icon crossed out.</p> <p>This symbol for no battery connection only shows in Software version 2.1 and 2.2.</p>

Chapter 8: CliniLogger™ Installation and Operating Instructions

Overview and Installation

Introduction

The purpose of the optional CliniLogger™ device is to save the CritiCool® MINI / CritiCool® / Allon® systems' vital data for further reference. By means of the CliniLogger™ Viewer software, the user can use an external PC to review this saved data.

Using the CliniLogger™ Application

The CliniLogger™ device connects to the RS-232 (serial) connector in the rear of the CritiCool® MINI for data transfer. While the device is connected, **data is saved at each one-minute interval.**

Connect the CliniLogger™ device to the CritiCool® MINI before the start of the medical procedure.

Belmont Medical Technologies recommends recording CritiCool® MINI device data for one patient at a time. At the end of the procedure, disconnect the CliniLogger™ device from the Thermoregulation machine and connect to a PC. Download the data from the device and then reconnect the CliniLogger™ to the Thermoregulation machine so it is ready for the next procedure.

The CliniLogger™ Software

The CliniLogger™ device is supplied with a CliniLogger™ Viewer software CD to be installed on a PC for downloading and viewing the saved data from the CritiCool® MINI. Alternatively, to download the software online, request the link from the Belmont technical service team at techsupport@belmontmedtech.com.

Installing the Software

To install the CliniLogger™ software:

1. On your PC, double-click on **My Computer** and open the CD drive.
2. Double-click the **Installer** folder.
3. Double-click the **Volume** folder
4. Double-click **setup**; the CliniLogger™ install window appears.

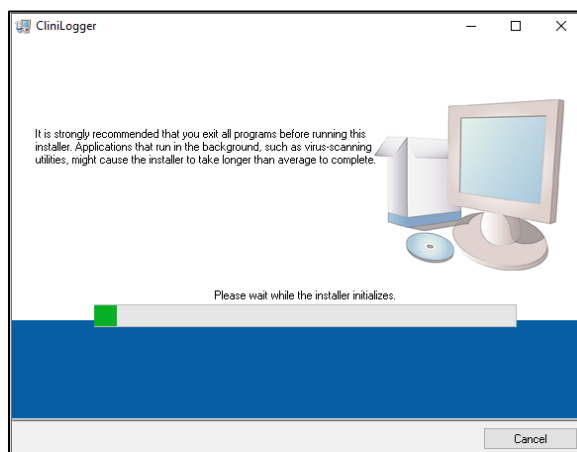

Figure 48: CliniLogger™ Initialization

When initialization finishes the following screen appears:

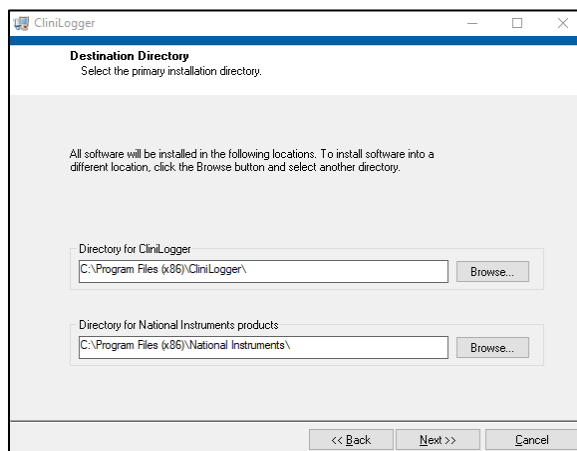

Figure 49: CliniLogger™ Installation

5. You can change the installation location by clicking Browse and selecting a new location. Click Next. The License Agreement window appears.

6. Select I accept the above License Agreement(s) to accept the license agreements and click Next. The Start Installation window appears.

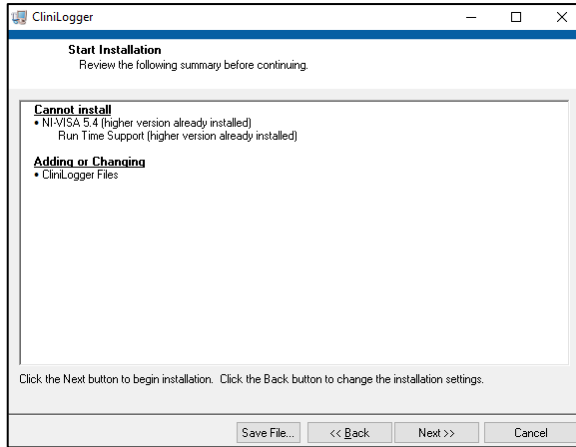

Figure 50: Start Installation

7. Click **Next**; you can follow the installation progress in the progress bars until it finishes.

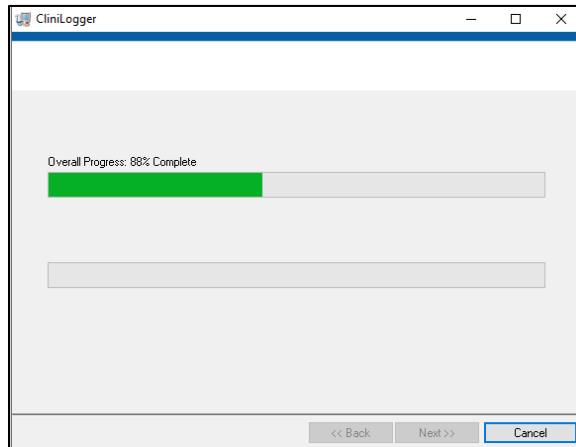

Figure 51: Installation in Progress

When the installation is finished, the **Installation Complete** window appears:

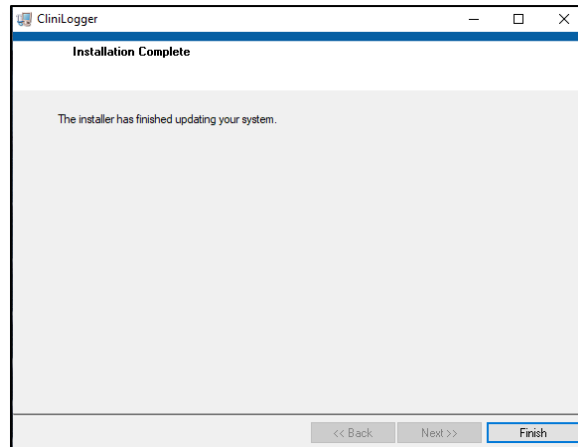

Figure 52: Installation Complete

8. Click **Finish** to complete and exit the software installation.
9. Copy "User Ver XX" folder from CD to your desktop.
10. You can now open "User Ver XX." folder and click the CliniLogger.exe file to start the application.

Using the CliniLogger™ Viewer Application

Downloading Data

You can download data from the CliniLogger™ Device to the CliniLogger™ Viewer Application on the PC.

To start the CliniLogger™ application:

1. From the Windows *Start* menu, click Programs > CliniLogger.
2. Click on the CliniLogger™ icon; the CliniLogger™ window appears.

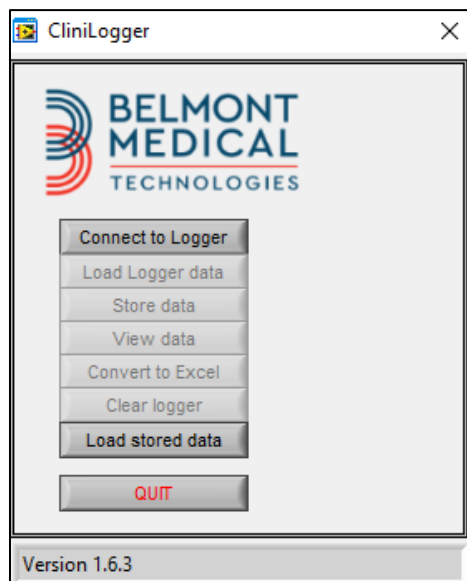

Figure 53: CliniLogger™ Application Window

3. Connect the CliniLogger™ device to the serial COM1 port of the PC.

NOTE: Verify that the CliniLogger™ device is connected to the COM 1 –10 port or you can use with USB to RS232 adaptor.

4. Click **Connect to Logger**, the software traces the COM port where the CliniLogger™ is connected – wait for the **Connected** message.
5. Click **Load Logger data**, wait for the **Complete** message.
6. Click **Store data** and choose a file and a location.
7. Click **View data**; the graph opens.
8. You can also click **Convert to Excel** to present the data in Excel format.
9. Click **Clear logger** after saving the data to prepare the device for the next use.

NOTE: You should erase the data on the CliniLogger™ manually after each patient, otherwise, the CliniLogger™ continues to burn data from the earliest patient on record on CliniLogger™.

Viewing Downloaded Data

To view downloaded data:

1. Double-click the CliniLogger™ Viewer icon. The CliniLogger™ window appears.

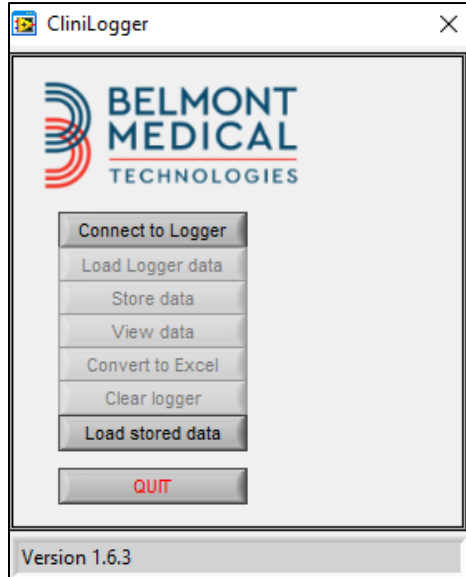

Figure 54: CliniLogger™ Window

2. Click **Load stored data** and choose the file you would like to view.

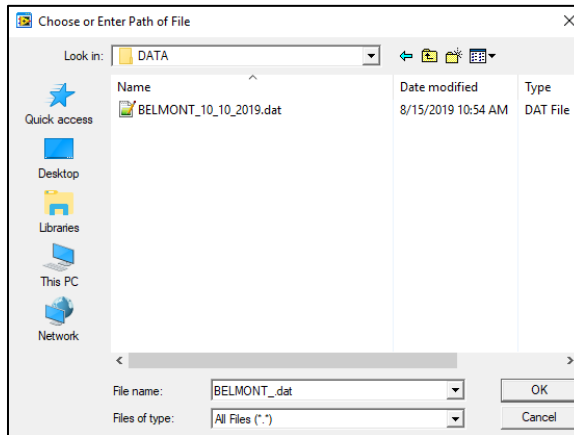

Figure 55: Choose CliniLogger™ File Window

When the data has been loaded, the “Complete” message appears

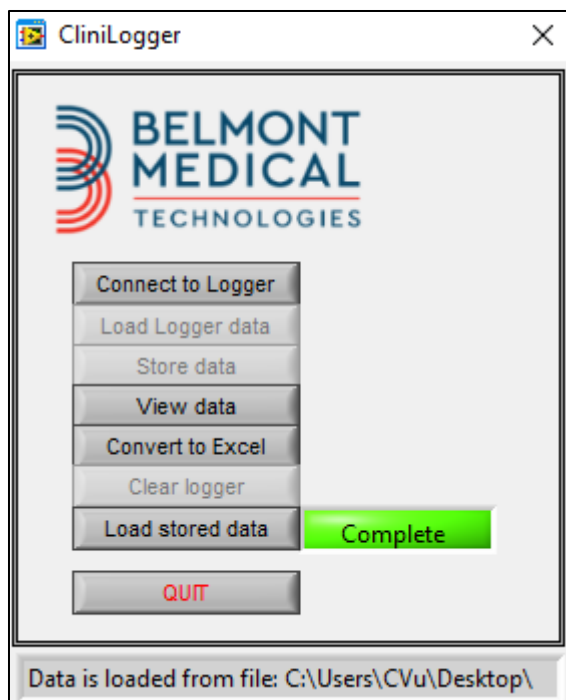

Figure 56: Complete Message

3. Click **View data** - the graph opens.
4. To convert to Excel, click **Convert to Excel** – the data is presented in Excel format.

CliniLogger™ Viewing Panel

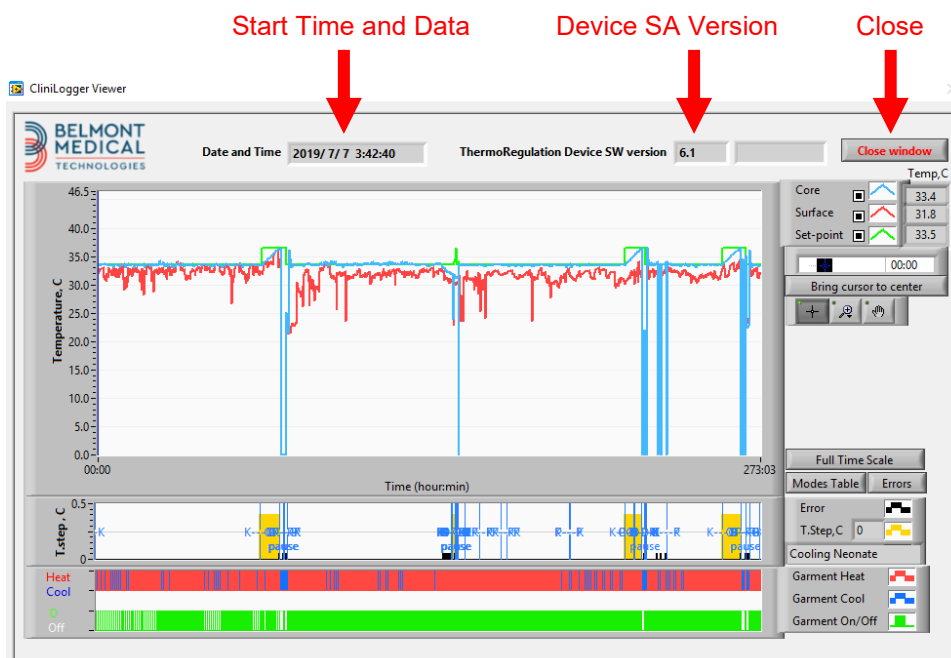

Figure 57: CliniLogger™ Viewing Panel

The CliniLogger™ viewing panel includes the following data:

- **Start date and time** received from the thermoregulation device (CritiCool® MINI)
- **Software version** of the thermoregulation device
- Close Window button
- Function Selection area: control keys
- Graphic Display area with a graphic presentation of the Thermoregulation system variables.

Graphic Display Area

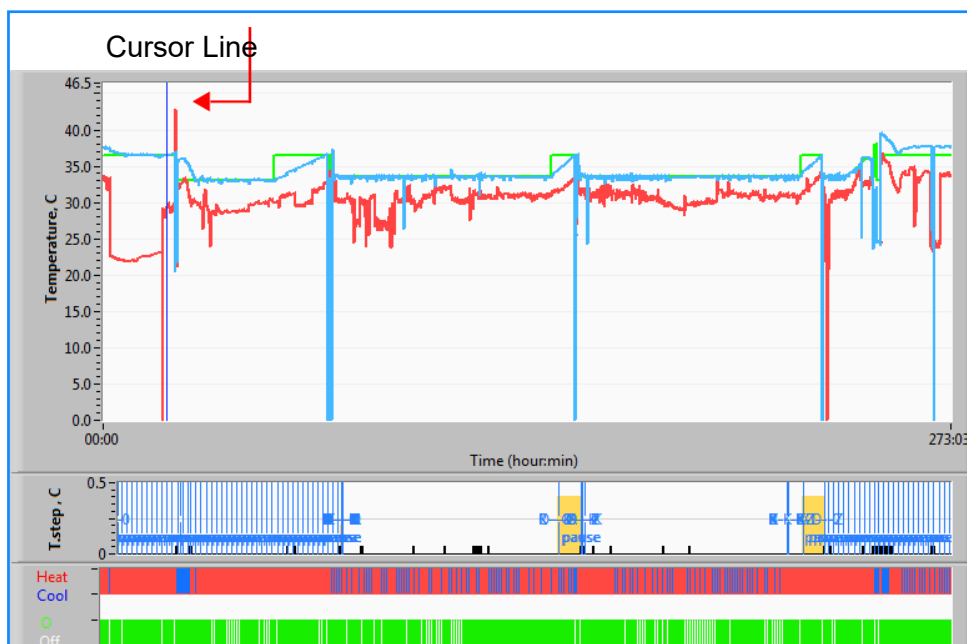

Figure 58: Graphic Display Area

The Graphic Display area consists of three parts:

- **Temperature graphs:** Set-point, Core and Surface as a function of time
- **Modes and Error area:** Thermoregulation modes, rewarming step and errors as a function of time
- **Device Functional Status area:** Heat/Cool and Pump On/Off

Function Selection Area

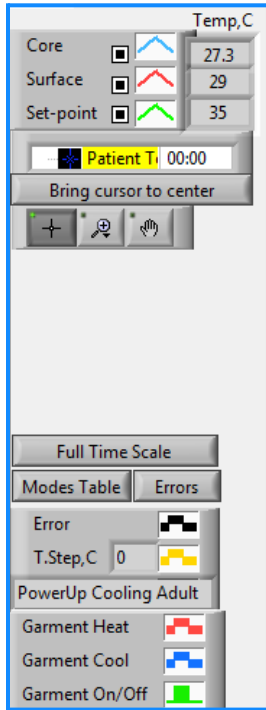

Figure 59: Example: Functional Status Area

The Function Selection area includes the keys that provide the ability to modify the Graphic Display area, such as zooming in and out, moving between time zones and detailing the viewed data.

Temperature Graph Control Buttons:

These buttons define the shape of the curves in the temperature graphs area, the water heat/cool graph and the water flow graph.

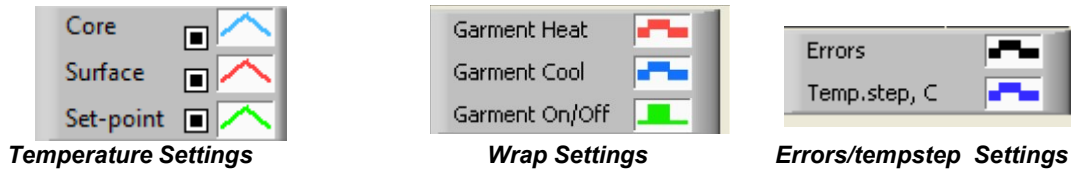

Figure 60: Example: Modes and Errors Area

Temperature graph control buttons enable modifying the display of each of the temperature graphs.

Display / Hide Buttons 

Use the Temperature Setting toggle buttons to Display / Hide each of the temperature graphs.

Color Buttons 

These buttons give the abilities to change the graph features and colors.

NOTE: *It is recommended to keep the default settings.*

View Manipulation Buttons

A set of three buttons is shown under the temperature buttons



Hand - Click the Hand  button, using the mouse move the hand cursor to the temperature graph area; and “grab” the curve by pressing the mouse left button and moving the mouse.

Moving the mouse horizontally will move the graphs horizontally - in time, and moving the mouse vertically, will move the graphs vertically - in temperature.

Zoom Clicking the Zoom button shows 6 modes of zoom use:

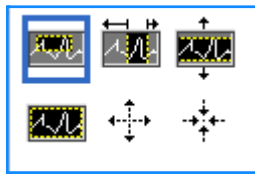







Table 16: Zoom Tool Buttons

Button	Click to...	How to use...
	Return the graphs to the default (un- zoomed) display	
	Zoom out symmetrically in X and Y directions	Click this zoom tool button. Using the mouse move the cursor to the Temperature graph; the cursor image changes to the button icon. Click the mouse to zoom out. You can click again to zoom out again.

Button	Click to...	How to use...
	Zoom in symmetrically in X and Y directions	Click this zoom tool button. Using the mouse move the cursor to the Temperature graph; the cursor image changes to the button icon. Click the mouse to zoom in. You can click again to zoom in again.
	Create an XY zoom in box.	Click this zoom tool button. Using the mouse move the cursor to the Temperature graph; the cursor image changes to zoom icon. Press the left mouse button and select the box in the graph for zooming in. Once you release the mouse button the image is zoomed in.
	Zoom in, in the X (Time) direction.	Click this zoom tool button, using the mouse move the Zoom tool cursor to the required point of time, click to insert the low limit line, keep the left key pressed and pull horizontally to the end of the time period desired. Once you release the mouse button the image is zoomed in.
	Zoom in, in the Y (Temperature) direction.	Use the mouse move the Zoom tool cursor to the lower temperature limit, click to insert the low limit line, keep the left key pressed and pull vertically. Release the key to view the temperature graphs zoomed in the selected vertical area.

To return to full time scale after zoom actions:

1. Click on .

The graph returns to the full-time range, without affecting the Temperature scale.

NOTE: To return to the original display, click the unzoom button .

Cursor Line

The values of the temperatures at the cursor line location appear in the window adjacent to the curve color window

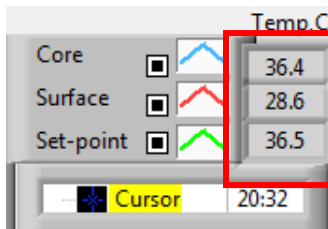



You can change the time of the Cursor Line on the graph (see Cursor Line in Graphic Display Area).

To set the time of the cursor:

1. Use the keyboard to set the required time in the **Cursor** textbox. Make sure to select the time as displayed on the graph (and in the HH:MM format).
2. Press ENTER.

The cursor moves to the selected time spot and the Temperatures displayed are the temperatures of the new spot.

To move the cursor line, in time (X direction)

3. Click the Cursor  icon.
4. Bring the + to the cursor location, the + will convert to a double line
5. Use the mouse to move the double line to a new cursor location. 

NOTE: The values of the temperature at the cursor location appear in the window adjacent to the curve color window

Modes and Error Area

This area provides the following information:

System mode marked by letters (See Mode Codes Table) and a vertical line.

Rewarming steps between 0°C and 0.5°C shown in the example in pink (the step was first 0.4°C and then changed to 0.2°C).

Error: Period with no control, in the example due to system pause (yellow markings).



Figure 61: Example of Modes and Error Area

Table 17: CliniLogger Mode Codes

Code	Indicates		
A	Powerup	Cooling	Adult
B	Powerup	Cooling	Neonate
C	Powerup	Warming	Adult
D	Powerup	Warming	Neonate
E	Powerup	Rewarm	Adult
F	Powerup	Rewarm	Neonate
G	Powerup	Standby	
H	Powerup	Sel.Mode	Adult
I	Powerup	Sel.Mode	Neonate
J	Cooling	Adult	
K	Cooling	Neonate	
L	Warming	Adult	
M	Warming	Neonate	
N	Rewarming	Adult	
O	Rewarming	Neonate	
P	Standby		
Q	Select Mode		Adult
R	Select Mode		Neonate

Functional Status Area – Heat/Cool and Pump On/ Power Off

The graphs indicate the state of the wrap: **Heat / Cool** modes and the **On/Off of water circulation** in the wrap.



Heat/Cool- When CritiCool® MINI is cooling the water in the tank, the line is blue. When the device is warming the water in the tank- the line is red.

Pump On/Off- When the pump is pumping water into the Wrap, the line is green. When CritiCool® MINI is circulating the water internally (i.e. In "Standby mode"), the line is white.

Converting to Excel

To convert to Excel:

1. On the CliniLogger™ menu panel select **Convert to Excel**; an Excel file opens with two options:

Measurement Table (Sheet 1)

	A	B	C	D	E	F	G
1	Date&Time	Record Time	Core	Surface	Set-Point	Mode	Errors
1161	2023/ 8/29 16:20:12	19:19	33.6	32.9	33.5 K		
1162	2023/ 8/29 16:21:32	19:20	33.6	32.9	33.5 K		
1163	2023/ 8/29 16:22:32	19:21	33.6	32.9	33.5 K		
1164	2023/ 8/29 16:23:32	19:22	33.6	32.9	33.5 K		
1165	2023/ 8/29 16:24:32	19:23	33.6	32.9	33.5 K		
1166	2023/ 8/29 16:25:32	19:24	33.6	32.9	33.5 K		
1167	2023/ 8/29 16:26:22	19:25	33.6	32.9	33.5 K		
1168	2023/ 8/29 16:26:52	19:26	33.6	32.8	33.5 K		
1169	2023/ 8/29 16:28:32	19:27	33.6	33	33.5 K		
1170	2023/ 8/29 16:29:32	19:28	33.5	33.1	33.5 K		
1171	2023/ 8/29 16:30:32	19:29	33.6	33.1	33.5 K		
1172	2023/ 8/29 16:31:32	19:30	33.6	33.1	33.5 K		
1173	2023/ 8/29 16:32:32	19:31	33.6	33.2	33.5 K		
1174	2023/ 8/29 16:33:32	19:32	33.6	33.2	33.5 K		
1175	2023/ 8/29 16:34:32	19:33	33.6	33.3	33.5 K		
1176	2023/ 8/29 16:35:22	19:34	33.6	33.4	33.5 K		
1177	2023/ 8/29 16:36:22	19:35	33.6	33.4	33.5 K		
1178	2023/ 8/29 16:37:32	19:36	33.5	33.4	33.5 K		
1179	2023/ 8/29 16:38:32	19:37	33.5	33.4	33.5 K		
1180	2023/ 8/29 16:39:27	19:38	33.5	33.5	33.5 K		

Figure 62: Section of Excel Table

Graphic Chart

A second page in the Excel file shows a graphic description of the Excel table with the Y axis showing the temperatures, and the X axis the Excel table lines.

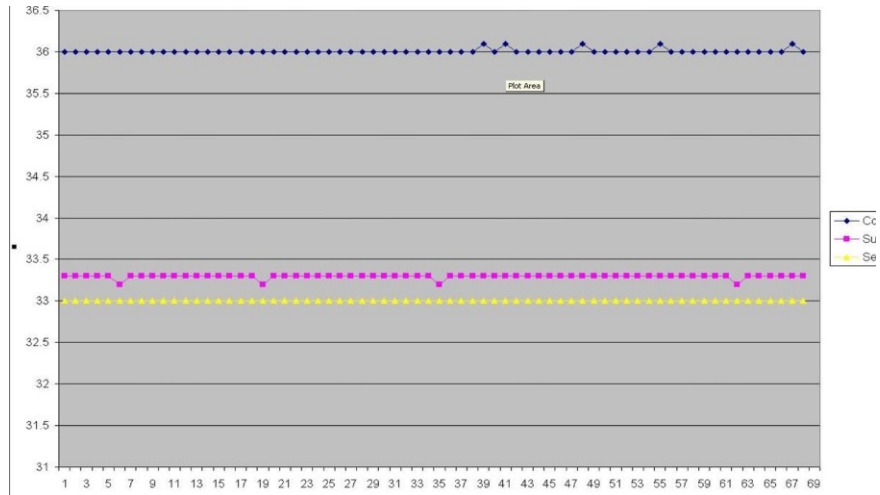

Figure 63: Section of Graphic Chart

Ending a Viewing Session

To end a session:

Click **Quit** on the Main Menu to exit the Viewing Session.

Technician Software

NOTE: *The Technician Software can only be run after performing a full installation of the User Software. See [‘Installing the Software’](#) section for more information on this process.*

Installation Procedure:

- Copy the folder “900-00350 CliniLogger Viewer Software_Tech v1.6.3” from the CD to a location on the desired PC
- Run the CliniLogger tech.exe application

Appendix A: EMI / EMC Information

WARNING!

Medical Electrical Equipment needs special precautions regarding EMC and needs to be installed and put into service according to the Electromagnetic Compatibility [EMC] information provided in the accompanying documents.

WARNING!

Portable RF communications equipment should be used no closer than 30 cm to any part of the device, otherwise degradation of the performance of this equipment could result

NOTE: *The EMC tables and other guidelines that are included in the Operators Manual provide information to the customer or user that is essential in determining the suitability of the Equipment or System for the Electromagnetic Environment of use, and in managing the Electromagnetic Environment of use to permit the Equipment or System to perform its intended use without disturbing other Equipment and Systems or non-medical electrical equipment.*

The essential performance features of CritiCool MINI are the accuracy of the temperature measurement system, the water temperature control, alarms if core temperature is unexpected, and halt conditions in case that any of the elements of the control mechanism fail.

Table 18: Guidance and Manufacturer’s Declaration—Emissions

Table 18: Guidance and Manufacturer’s Declaration—Emissions		
CritiCool® MINI is intended for use in the electromagnetic environment specified below. The customer or user of CritiCool® MINI should assure that it is used in such an environment.		
Emissions Test	Compliance	Electromagnetic Enforcement – guidance
RF Emissions CISPR 11	Group 1, Class A	The device should not be stacked with other equipment. Use of accessories and cables other than those specified by Belmont could result in increased electromagnetic emissions or decreased electromagnetic immunity of this equipment and result in improper operation.
Harmonics IEC 61000-3-2	Class A	Complies
Flicker IEC 61000-3-3	Complies	Complies

Table 19: Guidance and Manufacturer's Declaration—Immunity

<p>CritiCool® MINI is intended for use in the electromagnetic environment specified below. The customer or user of CritiCool® MINI should assure that it is used in such an environment.</p>	
Immunity Test	IEC 60601 Passed Parameters
IEC 61000-4-2 Electrostatic Discharge (ESD)	±8kv contact ±15kv air
IEC 61000-4-3 Radiated RF	10 V/m 80mhz-2.7ghz 80% AM @ 1khz
IEC 61000-4-3 Proximity field Immunity	385 mhz at 27 V/m, 18 Hz Pulse Modulation 450 mhz at 28 V/m, 1 khz Frequency Modulation ± 5 khz Dev 810 mhz, 870 mhz, and 930 mhz at 28 V/m, 18 Hz Pulse Modulation 710 mhz, 745 mhz, and 780 mhz at 9 V/m, 217 Hz Pulse Modulation 1720 mhz, 1845 mhz, and 2450 mhz at 28 V/m, 217 Hz Pulse Modulation 5240 mhz, 5500 mhz, and 5785 mhz at 9 V/m, 217 Hz Pulse Modulation
IEC 61000-4-4 Electrical Fast Transient/burst	±2kv on AC Mains 100khz Repetition frequency
IEC 61000-4-5 Surge	±1kv Line-to-line ±2kv Line-to-earth
IEC 61000-4-6 Conducted RF	3 Vrms from 150 khz to 80 mhz 6Vrms in ISM bands between 0.15 mhz and 80 mhz 80% AM @ 1 khz
IEC 61000-4-8 Power Frequency 50/60Hz Magnetic Field	30A/m
IEC 61000-4-11 Voltage dips, short interruptions, and voltage variations on power supply input lines	100% Dip for 0.5 Cycle @ 0°, 45°, 90°, 135°, 180°, 225°, 270°, and 315° 100% Dip for 1 Cycle 30% Dip for 25 Cycles 100% Dip for 5 Seconds

Appendix B: Waste Electrical & Electronic Equipment (WEEE)

The crossed-out wheel bin symbol on the product, literature, or packaging reminds you that all electrical and electronic products, batteries, and accumulators must be taken to separate collection at the end of their working life. This requirement applies to the European Union and other locations where separate collection systems are available. To prevent possible harm to the environment or human health from uncontrolled waste disposal, please do not dispose of these products as unsorted municipal waste, but instead, hand in at an official collection point for recycling.